

*Changes for the Better*

 **mitsubishi**  
PROGRAMMABLE CONTROLLERS  
MELSEC-F

## HARDWARE MANUAL

### FX<sub>2N</sub>-32CAN Communication Module

Industrial automation

**Elincom Group**

 European Union: [www.elinco.eu](http://www.elinco.eu)

 Russia: [www.elinc.ru](http://www.elinc.ru)

# FX<sub>2N</sub>



## **Foreword**

- This manual contains text, diagrams and explanations which will guide the reader in the correct installation and operation of the communication facilities of the FX2N-32CAN module.
- Before attempting to install or use the communication facilities of the FX2N-32CAN module, this manual and FX2N-32CAN User's Manual should be read and understood.
- If in doubt at any stage of the installation of the communication facilities of the FX2N-32CAN module always consult a professional electrical engineer who is qualified and trained to the local and national standards which apply to the installation site.
- If in doubt about the operation or use of the communication facilities of the FX2N-32CAN module please consult the nearest Mitsubishi Electric distributor.
- This manual is subject to change without notice.



# FX<sub>2</sub>N-32CAN Communication Module

## Hardware Manual

Manual number : JY992D92901

Manual revision : D

Date : November 2010

This manual confers no industrial property rights or any rights of any other kind, nor does it confer any patent licenses. Mitsubishi Electric Corporation cannot be held responsible for any problems involving industrial property rights which may occur as a result of using the contents noted in this manual.

## **Guidelines for the safety of the user and protection of the FX<sub>2N</sub>-32CAN Communication Module.**

This manual provides information for the use of the FX<sub>2N</sub>-32CAN Communication Module. The manual has been written to be used by trained and competent personnel. The definition of such a person or persons is as follows:

- a) Any engineer who is responsible for the planning, design and construction of automatic equipment using the product associated with this manual should be of a competent nature, trained and qualified to the local and national standards required to fulfill that role. These engineers should be fully aware of all aspects of safety with regards to automated equipment.
- b) Any commissioning or service engineer must be of a competent nature, trained and qualified to the local and national standards required to fulfill that job. These engineers should also be trained in the use and maintenance of the completed product. This includes being completely familiar with all associated documentation for said product. All maintenance should be carried out in accordance with established safety practices.
- c) All operators of the completed equipment (See Note) should be trained to use that product in a safe manner in compliance to established safety practices. The operators should also be familiar with documentation which is connected with the actual operation of the completed equipment.

**Note** : The term ‘completed equipment’ refers to a third party constructed device which contains or uses the product associated with this manual.

## Note's on the symbols used in this manual

At various times through out this manual certain symbols will be used to highlight points of information which are intended to ensure the users personal safety and protect the integrity of equipment. Whenever any of the following symbols are encountered its associated note must be read and understood. Each of the symbols used will now be listed with a brief description of its meaning.

### Hardware warnings



1) Indicates that the identified danger **WILL** cause physical and property damage.



2) Indicates that the identified danger could **POSSIBLY** cause physical and property damage.



3) Indicates a point of further interest or further explanation.

### Software warning



4) Indicates special care must be taken when using this element of software.



5) Indicates a special point which the user of the associate software element should be aware.



6) Indicates a point of interest or further explanation.

- Under no circumstances will Mitsubishi Electric be liable responsible for any consequential damage that may arise as a result of the installation or use of this equipment.
- All examples and diagrams shown in this manual are intended only as an aid to understanding the text, not to guarantee operation. Mitsubishi Electric will accept no responsibility for actual use of the product based on these illustrative examples.
- Please contact a Mitsubishi Electric distributor for more information concerning applications in life critical situations or high reliability.

## **Note Concerning the CE Marking**

This document does not guarantee that a mechanical system including this product will comply with the following standards. Compliance to EMC standards of the entire mechanical system should be checked by the user / manufacturer. Compliance to LVD standards of the entire mechanical system should be checked by the user / manufacturer.

## **EMC**

The following products have shown compliance through direct testing (of the identified standards below) and design analysis (through the creation of a technical construction file) to the European Directive for Electromagnetic Compatibility (2004/108/EC) when used as directed by the appropriate documentation. Refer to a manual or related material of each product other than the following.

## **Attention**

- This product is designed for use in industrial applications.

## **Note**

- Manufactured by: Mitsubishi Electric Corporation  
2-7-3 Marunouchi, Chiyoda-ku, Tokyo, 100-8310 Japan
- Manufactured at: Mitsubishi Electric Corporation Himeji Works  
840 Chiyoda-machi, Himeji, Hyogo, 670-8677 Japan
- Authorized Representative in the European Community:  
Mitsubishi Electric Europe B.V.  
Gothaer Str. 8, 40880 Ratingen, Germany

Type : Programmable Controller (Open Type Equipment)

Models : FX<sub>2N</sub>-32CAN manufactured

from November 1st, 2001 to April 30th, 2006 are  
compliant with EN50081-2 and EN61131-2:1994+A11:1996  
after May 1st, 2006 are compliant with EN61131-2:2007

Standard	Remark
EN50081-2:1993 Electromagnetic compatibility - Generic emission standard Industrial environment	Compliance with all relevant aspects of the standard. (Radiated Emissions)
EN61131-2:1994 Programmable controllers /A11:1996 - Equipment requirements and tests	Compliance with all relevant aspects of the standard. (RF Immunity, Fast Transients, ESD and Damped oscillatory wave)
EN61131-2:2007 Programmable controllers - Equipment requirements and tests	Compliance with all relevant aspects of the standard. (Radiated Emissions, Conducted Emissions, Radiated electromagnetic field, Fast transient burst, Electrostatic discharge, High-energy surge, Voltage drops and interruptions, Conducted RF and Power frequency magnetic field)

For more details, please contact the local Mitsubishi Electric sales site.

- Note for using the FX<sub>2N</sub>-32CAN

For compliance to EC EMC directive, install the FX<sub>1N</sub>/FX<sub>3G</sub>/FX<sub>2N</sub>/FX<sub>3U</sub>/FX<sub>2NC</sub>/FX<sub>3UC</sub> main unit, extension unit/block and the FX<sub>2N</sub>-32CAN in a shielded metal cabinet.



# Table of contents

Guideline .....	iii
1. Introduction.....	1-1
1.1 Features of the FX2N-32CAN Module.....	1-1
1.2 External Dimensions and Each Part Name .....	1-2
1.3 System configuration .....	1-4
1.4 Applicable PLC .....	1-4
2. Wiring .....	2-1
2.1 Caution for Wiring .....	2-1
2.3 Pin Configuration .....	2-2
3. Specifications .....	3-1
3.1 Environmental/Standards Specifications .....	3-1
3.2 Power Supply Specifications .....	3-1
3.3 Performance Specifications .....	3-2

4. Buffer Memory Structure .....	4-1
4.1 Basic Buffer Memory Structure, BFM #0 ~ BFM #31 .....	4-1
4.2 Buffer Memory Functions .....	4-2
4.2.1 Data Transfer Locations, BFMs #0~#19 and #100~#199 .....	4-2
4.2.2 The Data Exchange Mode, BFM #20 .....	4-2
4.2.3 Setting the Baud Rate, BFM #24.....	4-3
4.2.4 Reading the Communication Status, BFM #25 .....	4-4
4.2.5 The Watch Dog Timer Setting, BFM #26 .....	4-5
4.2.6 The Node Address, BFM #27 .....	4-5
4.2.7 Error Status, BFM #29.....	4-6
4.2.8 BFM Data Memory Backup .....	4-7
4.3 Extended BFM Structure, BFM #32 ~ BFM #32767 .....	4-8
5. Module Parameterization and Configuration .....	5-1
5.1 Factory Default Mapping/Mode 0 Mapping.....	5-3
5.2 Mode A Mapping .....	5-4
5.3 Mode B Mapping .....	5-5
5.3.1 Prepare the PDO Mapping Table .....	5-6
5.4 PDO Mapping Table Overviews .....	5-8
5.4.1 Tx-PDO Mapping Table.....	5-8
5.4.2 Rx-PDO Mapping Table .....	5-10

6. Diagnostics .....	6-1
6.1 LED Status .....	6-1
6.1.1 The Power LED .....	6-1
6.1.2 The FROM/TO LED .....	6-1
6.1.3 The RUN LED .....	6-2
6.1.4 The Rx/Tx LED .....	6-2
6.1.5 The ERROR LED .....	6-3
7. Example Program .....	7-1
7.1 SDO Write Command .....	7-2
7.2 Mode 0 Mapping Command .....	7-4
7.3 Mode A Mapping Example .....	7-5
7.4 Mode A Mapping with Node Start Up Command .....	7-6
7.5 Mode B Mapping Example with SDO Command .....	7-8
Appendix A:	
Further Information Manual Lists .....	A-1



# 1. Introduction

The FX2N-32CAN Communication Module is an interface block which connects the FX1N/FX3G/FX2N/FX3U/FX2NC/FX3UC PLC to an existing CANopen network. The CANopen network is an internationally accepted network for industrial automation.

For more information on the CANopen specifications please see the Can in Automation website at [www.can-cia.de](http://www.can-cia.de).

## 1.1 Features of the FX2N-32CAN Module

- A maximum of 120 words can be sent and received as Process Data Object (PDO) data. The number of words can be transmitted in each direction is set from 1 ~ 120.
- The buffer memory of the FX2N-CANopen Communication Module is read and written by FROM/TO instructions.
- Eight I/O points from the PLC expansion port are occupied in the PLC.
- The node address can be numbered from 1 to 127. A total of 30 nodes can be connected to any segment of the bus and by the use of repeaters or bridges, the total number can be extended up to 127 nodes.

## 1.2 External Dimensions and Each Part Name

Dimensions: mm (inches) MASS (Weight): 0.2 kg (0.44 lbs)

Accessory: Special block No. label

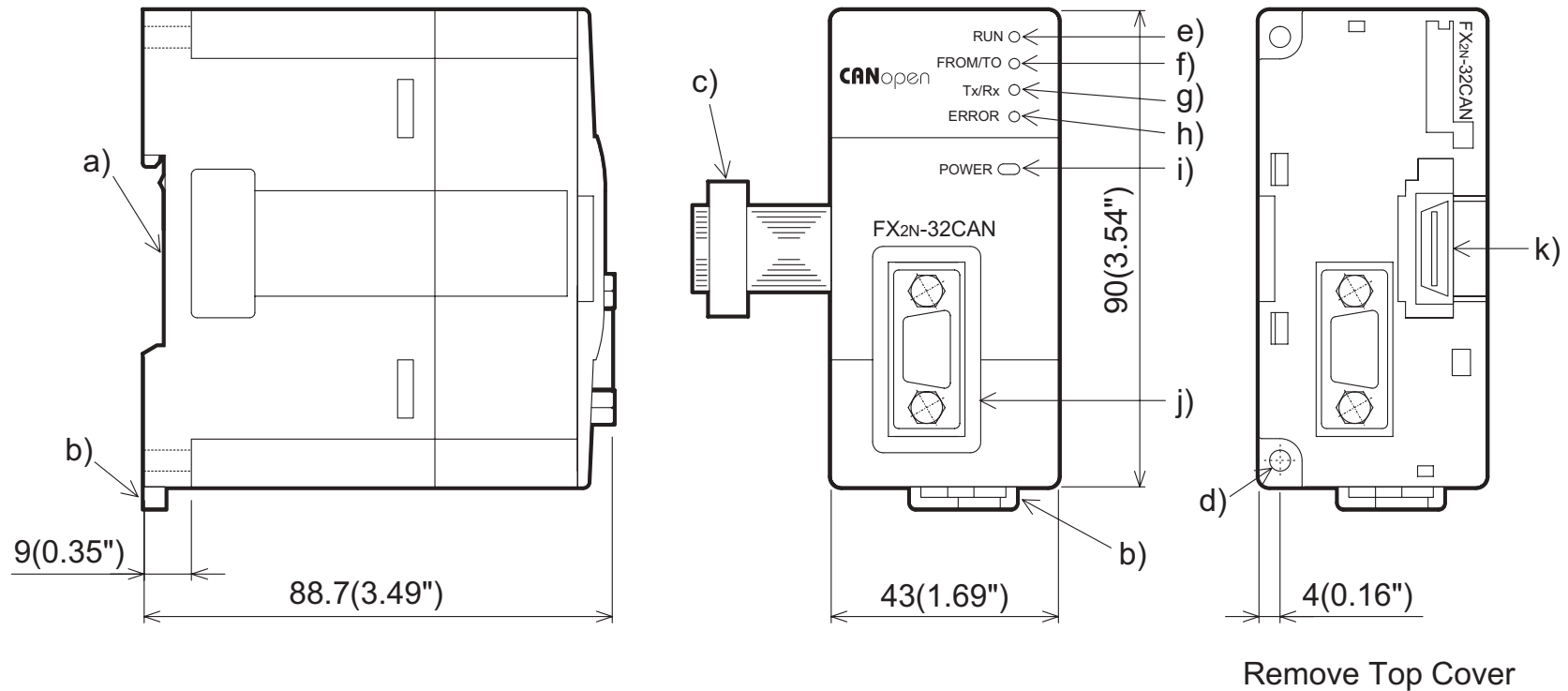

- a) Groove for DIN rail mounting (Width of DIN rail: 35 mm <1.38">)
- b) Hook for Din rail
- c) Extension cable
- d) Direct mounting holes (2- $\varnothing$ 4.5 mm <0.18">)
- e) RUN LED: Lights when the FX<sub>2N</sub>-32CAN Communication Module is in Run mode.
- f) FROM/TO: Lights when FROM/TO access is performed by the FX<sub>1N</sub>/FX<sub>3G</sub>/FX<sub>2N</sub>/FX<sub>3U</sub>/FX<sub>2NC</sub>/FX<sub>3UC</sub> PLC to the CANopen module.
- g) Tx/Rx: Lights up when the module is exchanging data.
- h) Error: Lights when a general error has occurred.
- i) POWER: Lights when 5 Volt power is supplied from the Programmable Controller.
- j) 9 Pin D-sub Connector
- k) Extension connector

### 1.3 System configuration

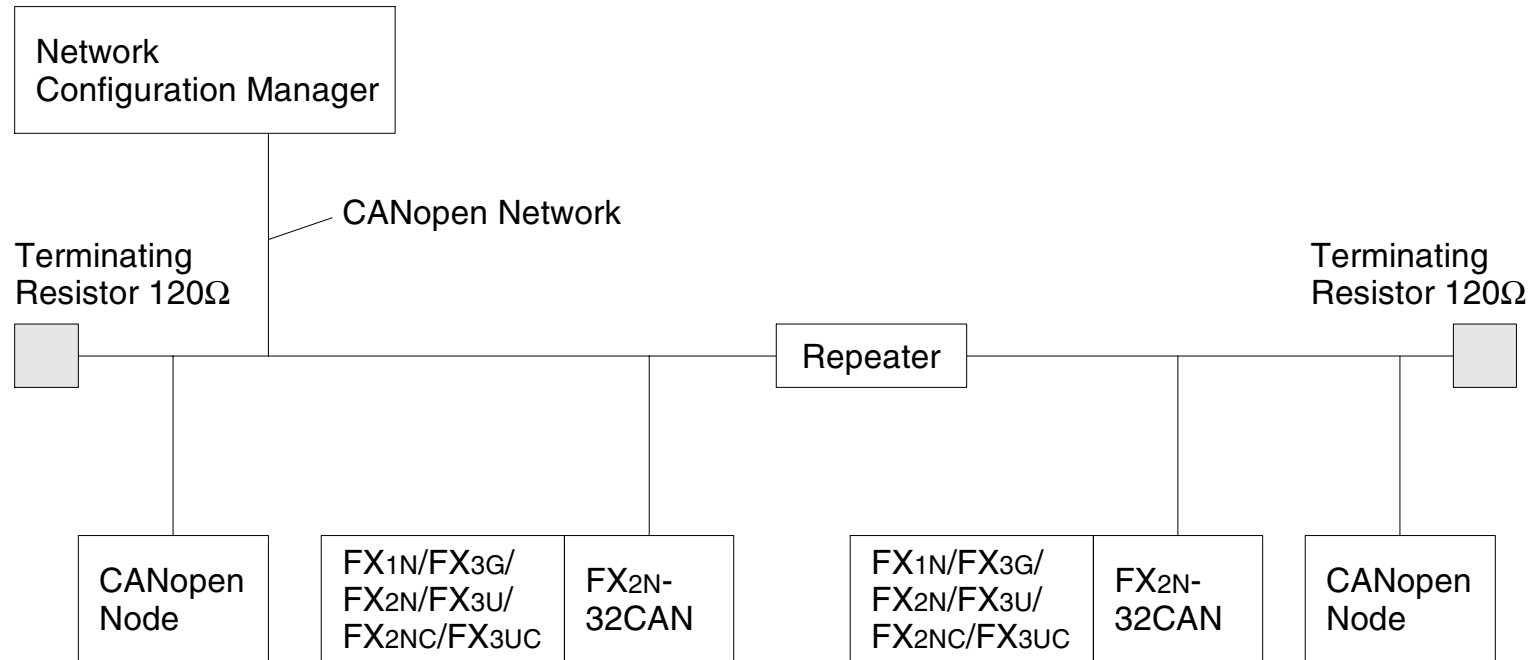

\*1 The Maximum extension distance for the FX2N-32CAN module is 5000m at 10kbps (with repeaters). The extension distance is reduced to 40m (130') at the maximum baud rate of 1 Mbps.

The maximum distance also depends on the specification of other connected CANopen nodes as well as the connectors and cables used.

### 1.4 Applicable PLC

FX2N-32CAN can be connected to the FX1N/FX3G/FX2N/FX3U/FX2NC/FX3UC Series PLC.



## 2. Wiring

### 2.1 Caution for Wiring



- 1) Do not lay signal cable near high voltage power cables or put them in the same trunking duct. Otherwise, the effects of noise or surge induction are likely to take place. Keep a safe distance of more than 100 mm (3.94") from these wires.
- 2) The terminal tightening torque is 0.5 to 0.8 N·m (5 to 8 kgf·cm). Tighten securely to avoid malfunction.
- 3) Cut off all phases of power source externally before installation or wiring work in order to avoid electric shock or damage to the product.

### 2.2 Cable

The cable should conform to ISO11898/1993.

The recommended cable is a shielded 2 x 2 twisted pair cable with an impedance of about 120 Ohm. (Example: UNITRONIC BUS LD 2 x 2 x 0.22 from company Lapp Kabel, [www.lappkabel.de](http://www.lappkabel.de)).

The bus line should be terminated on both ends by connectors that contain 120 Ohm termination resistors. Recommended is a connector which was designed to be used with CANopen networks (Example: ERbic series from company ERNI, [www.erni.com](http://www.erni.com)) but a normal 9 pin D-Sub female connector can be used.

## 2.3 Pin Configuration

The module connector below is a 9-pin D-SUB (#4-40 inc. inch screw thread) type.

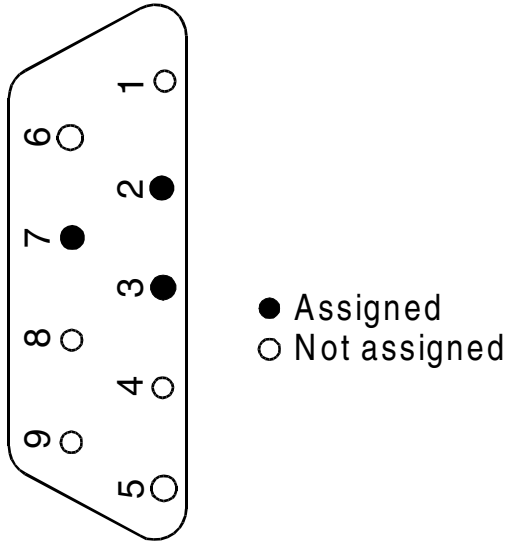

Pin No.	Signal	Meaning
2	Can_L	Can_L bus line, dominant low
3	Can_G	Can_Ground
7	Can_H	Can_H bus line, dominant high
1,4,5,6,8,9	NC	Pin not Assigned

### 3. Specifications

#### 3.1 Environmental/Standards Specifications

**Table 3.1: Environmental/Standards Specifications**

Item	Description
Environmental specifications excluding dielectric withstand voltage	Same as those of the main unit.
Dielectric Withstand Voltage	500 V AC > 1 min, tested between signal line and ground
CAN Standard	ISO 11898/1993
CANopen Standard by CiA	DS-301 Version 3.0
Additional CANopen Features	NMT, Guarding, and Guarding request based on DS-302 V2.0. Network Variables based on DS-405 V1.0

#### 3.2 Power Supply Specifications

**Table 3.2: Power Supply Specifications**

Item	Description
External Power Supply	None
Internal Current Consumption	130 mA at 5 V DC

### 3.3 Performance Specifications

**Table 3.3: Performance Specifications**

Item		Description
Maximum FX2N-32CAN Modules that can be connected to the CANopen network.		The node address can be set from 1 ~ 127. A total of 30 nodes can be connected on each bus. By the use of repeaters or bridges, the total number can be extended up to 127 nodes.
Supported Baud Rate		10 kbps, 20 kbps, 50 kbps, 125 kbps, 250 kbps, 500 kbps, 800 kbps, 1 Mbps
Number of Occupied I/O Points		8 points taken from either the input or output PLC I/O extension bus
Applicable Programmable Controller		FX1N, FX3G, FX2N, FX3U, FX2NC, FX3UC
Communication with Programmable Controller		FROM/TO instruction
LED Indication	RUN	Lit green when module is exchanging information with the CANopen network.
	FROM/TO	Lit green when module is receiving FROM/TO commands.
	Tx/Rx	Lit green when CAN-interface system is in normal operation.
	ERROR	Lit red when communication, overflow, or general error occurs.
	POWER	Lit green when the 5 V DC power supplied from main unit.

## 4. Buffer Memory Structure

### 4.1 Basic Buffer Memory Structure, BFM #0 ~ BFM #31

**Table 4.1: Buffer Memory Structure, BFM #0 - BFM #31**

BFM #	READ (FROM)	WRITE (TO)
BFM #0	Received data (Section 4.2.1-2)	Data to Transmit (Section 4.2.1-2)
BFM #1	Received data (Section 4.2.1-2)	Data to Transmit (Section 4.2.1-2)
⋮	⋮	⋮
BFM #19	Received data (Section 4.2.1-2)	Data to Transmit (Section 4.2.1-2)
BFM #20	Data exchange status bit (Section 4.2.2)	Data exchange control bit (Section 4.2.2)
BFM #21	Reserved	Reserved
BFM #22	Reserved	Reserved
BFM #23	Reserved	Reserved
BFM #24	Read baud rate (Section 4.2.3)	Set baud rate (Section 4.2.3, default 10kBd)
BFM #25	Module communication status (Section 4.2.4)	Reset + CANopen restart command (Section 4.2.4)
BFM #26	Read FROM/TO watchdog timer reload value, "default = 20" equals 200ms. (Section 4.2.5)	Set FROM/TO watchdog timer reload value, "default = 20" equals 200ms. (Section 4.2.5)
BFM #27	Read node address (Section 4.2.6)	Set node address, default = 127. (Section 4.2.6)
BFM #28	Reserved	Reserved
BFM #29	Error status (Section 4.2.7)	Reset latched error status (Section 4.2.7)
BFM #30	Module code (K7100)	(Read only)
BFM #31	Reserved	Reserved

## 4.2 Buffer Memory Functions

### 4.2.1 Data Transfer Locations, BFM #0~#19 and #100~#199

These Buffer memory locations in the FX<sub>2</sub>N-32CAN module are used to receive from and transfer data to the CANbus. The mapping for where each data is sent/received is explained in Chapter 5.

### 4.2.2 The Data Exchange Mode, BFM #20

On read access, BFM #20 contains a status bit for data exchange. If bit0 is “1”, the module is in data exchange mode and the received data are valid (no CAN error occurred). If bit0 is “0”, the module is not in data exchange mode.

On write access, BFM #20 acts as the data exchange control signal. To ensure that the FX<sub>2</sub>N-32CAN module can handle the PDO data in a consistent way, it is absolutely necessary to write a “1” to this BFM before reading Rx PDO data (FROM) and after writing Tx-PDO data (TO) to the module. The data exchange control signal ensures, by internal buffer exchange, that TO data from the PLC will be transmitted within the same corresponding Tx-PDO at the same time.

TO data will only be sent to the CAN bus after a write access to BFM #20 (data = 1).

As long as the reading of the previous data is not finished and a new exchange command to BFM #20 has not been sent, FROM data from the CAN bus will not be (partially) overwritten by further Rx PDOs with the same ID.

If the CAN open module is in data exchange mode, the received PDO data (Rx-PDO) from other nodes can be read by the FX<sub>2</sub>N(C)/FX<sub>1</sub>N PLC by using a FROM instruction and the transmit PDO data (Tx-PDO) can be written to the module and sent to the network by using a TO instruction.

### 4.2.3 Setting the Baud Rate, BFM #24

BFM24 shows the current baud rate of the CANopen network, see the Table below. The baud rate can be set by writing TO BFM #24. The baud rate must be equal for all nodes on the CANopen network.

**Table 4.2: Baud Rate Settings**

Baud Rate	BFM #24 Value
10 kbps	10
20 kbps	20
50 kbps	50
125 kbps	125
250 kbps	250
500 kbps	500
800 kbps	800
1000 kbps	1000

#### 4.2.4 Reading the Communication Status, BFM #25

Read the CANopen module's communication status from BFM #25 per the table below.

**Table 4.3: Communication Status**

Bit	On	Off
b0: module online/offline	module online	module offline
b1 ~ b7: reserved		
b9, b8: CANopen network state	00 <sub>b</sub> = Prepared State 01 <sub>b</sub> = Pre-operational State 10 <sub>b</sub> = Operational State 11 <sub>b</sub> = Not Possible	
b10 ~ b15: reserved		

*Note: On write access, BFM #25 contains the command flags to reset the FX2N-32CAN and to restart the CAN open stack.*

**Table 4.4: CANopen Stack Reset**

Bit	On	Off
b0: restart command	CANopen stack will be restarted	Normal operation
b1 ~ b15: reserved		

The restart command can be used after the baud rate (BFM #24) or the node address (BFM #27) was changed. By setting B0 to "1" (use the pulse instruction), the module can be forced to go offline and to restart with the new settings without switching off the power of the host PLC.



#### 4.2.5 The Watch Dog Timer Setting, BFM #26

The Watch Dog Timer setting is stored in BFM #26 in units of 10 ms. A WDT error will occur if there is no FROM or TO instruction to any BFM for the time specified. After the WDT has expired, it must be reset by writing the current or a new value to BFM #26. When the value 0 is written to BFM #26, the FROM/TO watchdog timer is disabled.

During normal operation as soon as the module receives a FROM or TO instruction, the WDT will reset to time zero.

Note: No Emergency Message will be transmitted if the WDT is disabled and the FROM/TO communication stops and the FX<sub>2N</sub>-32CAN module is in operational mode.

#### 4.2.6 The Node Address, BFM #27

The CANopen node supports setting of the node address by the FX<sub>1N</sub>/FX<sub>3G</sub>/FX<sub>2N</sub>/FX<sub>3U</sub>/FX<sub>2NC</sub>/FX<sub>3UC</sub> PLC via the TO instruction. The actual address is displayed in BFM #27. The Node address must be set for communication to take place via the CANopen bus.

In case of an address change by TO instruction, the new address value (1...127<sub>d</sub>) must be written to BFM #27. The new address will only become effective after a power down of the host PLC or after a restart command written to BFM #25.

#### 4.2.7 Error Status, BFM #29

BFM #29 reflects the error status of the module. Bit 7 shows the status of the FROM/TO watchdog timer (see section 4.1.7, BFM #26). In case of a watchdog timer error (b7 is ON) an external emergency message will be sent to the CANopen network if the module is in operational mode.

When the value 0 is written to BFM #26, the FROM/TO watchdog timer is disabled and b7 of BFM #29 will never become “1”.

**Table 4.5: Error Bit Description for BFM #29**

Bit	On	Off
b0: general error	This bit is ON if b2, b3 or b4 are On	No general error
b1: reserved		
b2: power error	Power supply error	Power supply normal
b3: CAN bus off error	CAN bus off error	
b4:EEPROM/flash memory error	Data in EEPROM or flash memory is corrupted	EEPROM and flash memory data normal
b5, b6: reserved		
b7: FROM/TO watchdog timer (reset by writing a value to BFM #26)	No FROM/TO instruction received (for the time specified in BFM #26)	FROM/TO instructions received regularly
b8: Data queue overflow	Data could not be written to internal queue	No data queue overflow

**Table 4.5: Error Bit Description for BFM #29**

Bit	On	Off
b9: Command queue or event queue overflow	Data could not be written to internal command queue or event queue	No command queue or event queue overflow
b10: CANopen guarding error	CANopen guarding error occurred	No CANopen guarding error occurred
b11: Baud rate change error	New baud rate not valid, no change	Set baud rate valid
b12: Address change error	New address not valid, no change	Address is valid
b13: CANopen emergency	CANopen emergency occurred	No emergency exists
b14: CAN error passive state	CAN error passive	CAN error active
b15: Reserved		

**NOTE:**

1. The error bits b2, b8, b9, and b14 are latched and must be reset from the PLC by writing “0” to the appropriate bit in BFM #29. By writing “0” to all of BFM #29, all latched error flags will be cleared.
2. All other error flags will be reset automatically as soon as the corresponding error has been solved.

**4.2.8 BFM Data Memory Backup**

The data in BFM #24, #26, and #27 are kept by EEPROM.

### 4.3 Extended BFM Structure, BFM #32 ~ BFM #32767

**Table 4.6: Extended BFM Structure**

BFM #	READ (FROM)	WRITE (TO)
BFM #32 ~ #99	Reserved	Reserved
BFM #100 ~ #199	Received Output Data	Transmit Data
BFM #200 ~ #999	Reserved	Reserved
BFM #1000 ~ #1066	Module Command Interface	Module Command Interface
BFM #1067 ~ #32767	Reserved	Reserved

The module command interface offers the possibility to send commands directly to the CANopen module. This command interface can be used to manipulate and control all items in the object dictionary, to send and receive SDO messages, to send network management messages, or to send emergency messages.

Please see the FX<sub>2N</sub>-32CAN User's Manual for more information.

## 5. Module Parameterization and Configuration

Each CANOpen node must have certain parameters defined in order to communicate information to other CANOpen nodes. These parameters include the Node Number, the baud rate, the Watch Dog Timer setting (specific for FX2N-32CAN module), and the communication mapping set.

The CANopen network has a defined Object Dictionary for parameters and data communication. The FX1N/FX3G/FX2N/FX3U/FX2NC/FX3UC PLC can write this information to the CANbus through the buffer memory addresses of the FX2N-32CAN module.

A network configuration tool is a powerful device for setting the parameter data for any manufacturers node (including the FX2N-32CAN) and defining the data mapping connection set. It is recommended to use a network configuration tool for large networks due to the convenience, flexibility, and ease of use that the tools provide.

To build up a small network or for testing purposes, the module Command InterFace (hereafter called the CIF) supports three PDO mapping/binding commands designed for and supported by the FX2N-32CAN module. Example PLC programs are given in Chapter 7. By using these predefined Mapping configurations, the CAN object ID (COB-ID) number for data exchange for each node is clearly defined. For example an Rx-PDO (receive process data object) can be connected to a Tx-PDO (transmit process data object) of another node. These data will always be transmitted with the same COB-ID and every node can distinguish relevant data by checking the COB-ID.

*Note: It is strongly recommended to execute the Mapping Commands only in the pre-operational or stopped mode of the local and all related CANopen nodes.*

## Vocabulary Terms

Rx-PDO - Recieve Process Data Objects are data read from other nodes via the CAN bus.

Tx-PDO - Transmit Process Data Objects are the data sent to other nodes via the CAN bus.

CIF - The Command InterFace is the FX2N-32CAN tool used to perform actions such as to set parameters, execute commands, establish communication connections, access the CANopen Object Dictionary, and read error messages. It is located in BFM #1000~#1066.

COB-ID - The CAN Object ID number is a unique identifying number to distinguish between different messages on the CANBus (e.g. PDO, SDO, NMT, SYNC, EMCY messages)

BFM - The Buffer Memory is the data storage memory location.

Mapping Mode 0 - Base Configuration where 4 Rx-PDOs and 4 Tx-PDOs are given BFM assignments for each FX2N-32CAN node according to the pre-defined connection set of CANopen.

Mapping Mode A - Mitsubishi Electric defined configuration for the FX2N-32CAN module that defines the relationship between up to eight FX2N-32CAN nodes, the node BFMs, and the Rx-PDOs and Tx-PDOs. This mode is very convenient if every node is an FX2N-32CAN module.

Mapping Mode B - Configuration mode that allows specific Rx-PDOs and Tx-PDOs to be matched on a node by node basis.

For more detailed information on all the features and capabilities of the FX2N-32CAN module please refer to the FX2N-32CAN User's Manual.

For more information on the CANopen specifications please see the Can-in-Automation website at [www.can-cia.de](http://www.can-cia.de).

## 5.1 Factory Default Mapping/Mode 0 Mapping

The Factory Default Mapping conforms to CANopen specification DS-301 and contains only the first 2 Tx-PDOs and the first two Rx-PDOs. Please refer to the two Tables in section 5.4 that give, repetitively, the relationships between Tx-PDO number/COB-IDs/BFM# and the Rx-PDO/COB-IDs/BFM#.

By executing the Mode 0 mapping command shown below the number of automatically assigned Tx-PDOs becomes four instead of two. Four Rx-PDOs are also mapped automatically.

**Table 5.1: Mode 0 Mapping Command**

BFM #	READ (FROM)	WRITE (TO)
BFM #1000	Mapping successfully established (8901)	Command (8900 hex)
BFM #1001	Unused	Unused
:	Unused	Unused
BFM #1066	Unused	Unused

The BFM #0 - #15 are distributed to Rx-PDOs 1-4 and Tx-PDOs 1-4 as shown in section 5.4. This setting is useful for a network that features many different types of node or as a base for a network mapping configured with the Mode B mapping command.

The PDOs from 5-30 (BFM #16 ~ #19 and BFM #100 ~ #199) are disabled in the default settings but further mapping of BFM #16 ~ #19 and BFM #100 ~ #199 can be accomplished using the Mode B mapping technique.

## 5.2 Mode A Mapping

Setting up a CANopen network of only FX<sub>2N</sub>-32CAN nodes can be accomplished by simply using the Mode A Mapping configuration. Other types of CANopen modules can be added to the Network but additional user inputs are necessary.

**Table 5.2: Mode A Mapping Command**

BFM #	READ (FROM)	WRITE (TO)
BFM #1000	Mapping successfully established (8201 hex). Local node number MUST be in the range 1 - 8 (82FF hex)	Command (8200 hex)
BFM #1001	Unused	Unused
:	Unused	Unused
BFM #1066	Unused	Unused

To establish communication between a FX<sub>2N</sub>-32CAN node and up to 7 other FX<sub>2N</sub>-32CAN nodes it is only necessary to write the “set Mode A Mapping” command (8200 hex) via the local PLC of every FX<sub>2N</sub>-32CAN. One of the nodes must be configured as the network manager. The network manager can be defined in the Network Configuration tool or by writing to the Object Dictionary using the CIF SDO write command. See Chapter 7 for example programs.



When all the stations have executed the Mode A Mapping command, it is possible to exchange 16 data words with every other FX<sub>2N</sub>-32CAN module\*. Due to the data size, the number of nodes in this mapping Mode is limited to 8 stations. *If the node number is outside the range 1-8, BFM #1000 will display the “node number mismatch” error message (82FF hex).*

\*Note: Nodes 1 - 7 can exchange 16 words of data with every other node but station number 8 can send just 8 words of data to the other 7 stations. Node 8 can read the 16 words of data from all the other stations.

To include other types of CANopen nodes in the Mode A network, it is necessary to change the Rx-PDO and communication parameters of these stations. This can be done by the Mode B mapping commands, the SDO write access Command, or by a standard configuration tool.

### 5.3 Mode B Mapping

With Mode B Mapping, it is possible to build up a binding (a connection between two node addresses) between all nodes connected to the FX<sub>2N</sub>-32CAN module. Also, the binding of any CANopen node with any other node is supported. The Mode B mapping is limited to the binding of the PDOs which are already configured in the remote stations (no change of the mapping between CANopen data and the remote node’s hardware) which will be suitable for most cases.

### 5.3.1 Prepare the PDO Mapping Table

The Mode B mapping command will modify or add to the current PDO mapping, therefore it is important to have a clearly defined mapping base before executing any Mode B commands. Executing the Mode B Mapping commands before creating a PDO mapping base may create errors in the data transmission or module operation.

The PDO mapping base can be the “Mode 0” mapping or the “Mode A” mapping explained in previous sections to prepare the default Rx-PDO and Tx-PDO formats as shown in section 5.4. Another method to create (or reset) a Mapping base is to initialize the Mode B Mapping with a special instruction at the beginning of the Mode B Mapping Command.

The purpose of the Mode B Mapping Commands is to bind a Tx-PDO from one CANopen node to a Rx-PDO of another node. This allows certain Buffer Memory information to be transferred/read in designated nodes around the CANopen network.

The Source parameter specifies the Node number and the specific Tx-PDO. The Destination parameter specifies the Node number and the specific Rx-PDO that can read the data. The command consists of four hexadecimal numbers, the two higher byte numbers specify the node number and the two lower numbers specify the appropriate PDO number.

**Table 5.3: Mode B Mapping Command**

BFM #	READ (FROM)	WRITE (TO)
BFM #1000	Binding done without errors - 8301 H. Binding error occurs - Hex 83FF H. CIF BUSY (FFFFh)	Command (8300 hex)
BFM #1001	Diagnosis Data: 0000 hex = no error  All other Values: The Corresponding parameter cause an error (BFM #1000 will be 83FF hex)	Source 1 [*1]
BFM #1002		Destination 1 [*2]
BFM #1003		Source 2 [*1]
BFM #1004		Destination 2 [*2]
BFM #1005		Source 3 [*1]
BFM #1006		Destination 3 [*2]
⋮		⋮
⋮		⋮
BFM #1065		Source 33 [*1]
BFM #1066		Destination 33 [*2]

Note: The parameter set must be terminated by the “end of binding Table” parameter. This is accomplished by setting the Source parameter that follows the final binding parameter to FFFF hex.

With one execution of the Mode B mapping command up to 33 binding connections between CANopen stations can be made. To establish more data connections, the command can be repeated as often as necessary.

## 5.4 PDO Mapping Table Overviews

### 5.4.1 Tx-PDO Mapping Table

**Table 5.4: Tx-PDO Mapping Table**

	Default Factory/Mode 0 Mapping*	Mode A Mapping	Mode B Mapping (after PDO mapping is prepared)	Assigned BFM
	<b>COB ID</b>			<b>Mapped BFMs (access style)</b>
Tx-PDO 1		0180 hex + node ID		BFM #3 ... BFM #0 (TO)
Tx-PDO 2		0280 hex + node ID		BFM #7 ... BFM #4 (TO)
Tx-PDO 3		0380 hex + node ID		BFM #11 ... BFM #8 (TO)
Tx-PDO 4		0480 hex + node ID		BFM #15 ... BFM #12 (TO)
Tx-PDO 5	Disabled (COB-ID set to 80000000 hex). These PDOs can be activated by mode B mapping commands.		Disabled (COB-ID set to 80000000 hex). Can be defined by mode B mapping command parameter.	BFM #19 ... BFM #16 (TO)
Tx-PDO 6				BFM #103 ... BFM #100 (TO)
Tx-PDO 7				BFM #107 ... BFM #104 (TO)
Tx-PDO 8				BFM #111 ... BFM #108 (TO)
Tx-PDO 9				BFM #115 ... BFM #112 (TO)
Tx-PDO 10				BFM #119 ... BFM #116 (TO)
Tx-PDO 11				BFM #123 ... BFM #120 (TO)
Tx-PDO 12				BFM #127 ... BFM #124 (TO)
Tx-PDO 13				BFM #131 ... BFM #128 (TO)
Tx-PDO 14				BFM #135 ... BFM #132 (TO)

**Table 5.4: Tx-PDO Mapping Table**

	Default Factory/Mode 0 Mapping*	Mode A Mapping	Mode B Mapping (after PDO mapping is prepared)	Assigned BFM
Tx-PDO 15	Disabled (COB-ID set to 80000000 hex) These PDOs can be activated by mode B mapping commands.		Disabled (COB-ID set to 80000000 hex). Can be defined by mode B mapping command parameter.	BFM #139 ... BFM #136 (TO)
Tx-PDO 16				BFM #143 ... BFM #140 (TO)
Tx-PDO 17				BFM #147 ... BF M#144 (TO)
Tx-PDO 18				BFM #151 ... BFM #148 (TO)
Tx-PDO 19				BFM #155 ... BFM #152 (TO)
Tx-PDO 20				BFM #159 ... BFM #156 (TO)
Tx-PDO 21				BFM #163 ... BFM #160 (TO)
Tx-PDO 22				BFM #167 ... BFM #164 (TO)
Tx-PDO 23				BFM #171 ... BFM #168 (TO)
Tx-PDO 24				BFM #175 ... BFM #172 (TO)
Tx-PDO 25				BFM #179 ... BFM #176 (TO)
Tx-PDO 26				BFM #183 ... BFM #180 (TO)
Tx-PDO 27				BFM #187 ... BFM #184 (TO)
Tx-PDO 28				BFM #191 ... BFM #188 (TO)
Tx-PDO 29	BFM #195 ... BFM #192 (TO)			
Tx-PDO 30	BFM #199 ... BFM #196 (TO)			

### 5.4.2 Rx-PDO Mapping Table

**Table 5.5: Rx-PDO Mapping Table**

Rx-PDO#	Default Factory/ Mode 0 Mapping*	Mode A Mapping	Mode B Mapping (after PDO Mapping is prepared)	Assigned BFM	
	<b>COB ID</b>			<b>Mapped BFMs (access style)</b>	
Rx-PDO 1	0200 hex + node ID	181 hex	Disabled (COB-ID set to 80000000 hex). Can be defined by mode B mapping command parameter.	BFM #3 ... BFM #0 (FROM)	
Rx-PDO 2	0300 hex + node ID	281 hex		Node 1 data	BFM #7 ... BFM #4 (FROM)
Rx-PDO 3	0400 hex + node ID	381 hex			BFM #11 ... BFM #8 (FROM)
Rx-PDO 4	0500 hex + node ID	481 hex			BFM #15 ... BFM #12 (FROM)
Rx-PDO 5	Disabled (COB-ID set to 80000000 hex). These PDOs can be activated by Mode B mapping commands.	182 hex			Node 2 data
Rx-PDO 6		282 hex		BFM #103 ... BFM #100 (FROM)	
Rx-PDO 7		382 hex		BFM #107 ... BFM #104 (FROM))	
Rx-PDO 8		482 hex		BFM #111 ... BFM #108 (FROM)	
Rx-PDO 9		183 hex		Node 3 data	BFM #115 ... BFM #112 (FROM)
Rx-PDO 10		283 hex			BFM #119 ... BFM #116 (FROM)
Rx-PDO 11		383 hex			BFM #123 ... BFM #120 (FROM)
Rx-PDO 12		483 hex			BFM #127 ... BFM #124 (FROM)
Rx-PDO 13		184 hex		Node 4 data	BFM #131 ... BFM #128 (FROM)
Rx-PDO 14		284 hex			BFM #135 ... BFM #132 (FROM)
Rx-PDO 15		384 hex			BFM #139 ... BFM #136 (FROM)
Rx-PDO 16		484 hex			BFM #143 ... BFM #140 (FROM)

**Table 5.5: Rx-PDO Mapping Table**

Rx-PDO#	Default Factory/ Mode 0 Mapping*	Mode A Mapping	Mode B Mapping (after PDO Mapping is prepared)	Assigned BFM	
Rx-PDO 17	Disabled (COB-ID set to 80000000 hex). These PDOs can be activated by Mode B mapping commands.	185 hex	Disabled (COB-ID set to 80000000 hex). Can be defined by mode B mapping com- mand parameter.	BFM #147 ... BFM #144 (FROM)	
Rx-PDO 18		285 hex		BFM #151 ... BFM #148 (FROM)	
Rx-PDO 19		385 hex		BFM #155 ... BFM #152 (FROM)	
Rx-PDO 20		485 hex		BFM #159 ... BFM #156 (FROM)	
Rx-PDO 21		186 hex		Node 6 data	BFM #163 ... BFM #160 (FROM)
Rx-PDO 22		286 hex			BFM #167 ... BFM #164 (FROM)
Rx-PDO 23		386 hex			BFM #171 ... BFM #168 (FROM)
Rx-PDO 24		486 hex		Node 7 data	BFM #175 ... BFM #172 (FROM)
Rx-PDO 25		187 hex			BFM #179 ... BFM #176 (FROM)
Rx-PDO 26		287 hex			BFM #183 ... BFM #180 (FROM)
Rx-PDO 27		387 hex			BFM #187 ... BFM #184 (FROM)
Rx-PDO 28		487 hex		Node 8 data	BFM #191 ... BFM #188 (FROM)
Rx-PDO 29		188 hex			BFM #195 ... BFM #192 (FROM)
Rx-PDO 30		288 hex			BFM #199 ... BFM #196 (FROM)

\* The Factory Default Mapping contains only the first two Rx-PDOs and the first two Tx-PDOs as defined in DS-301. Mode 0 mapping sets the first four Rx-PDOs and Tx-PDOs as shown in the Tables.

# MEMO



## 6. Diagnostics

### 6.1 LED Status

To show that all LEDs are working, they will all be switched On for a short time after power On. After that, the status of the LEDs depends on the LED status of the module.

#### 6.1.1 The Power LED

The power LED is lit green when 5V power is supplied from the programmable controller. If it is not lit, check to see if the extension cable is properly connected.

#### 6.1.2 The FROM/TO LED

This LED is lit green when FROM/TO access is performed by the FX<sub>1N</sub>/FX<sub>3G</sub>/FX<sub>2N</sub>/FX<sub>3U</sub>/FX<sub>2NC</sub>/FX<sub>3UC</sub> PLC to the FX<sub>2N</sub>-32CAN module. If there is no FROM/TO access for a longer period of time than is specified in BFM #26, this LED will turn Off (FROM/TO WDT error).

Note: There are some cases where the FROM/TO instruction will be accessed on every scan by an outside device. In these instances, the WDT error will not occur. Some examples of this occurrence are when the Special Function Unit's Buffer Memory is being monitored by GX Developer or another software program or if an FX<sub>1N</sub>-5DM is connected to an FX<sub>1N</sub> PLC.

As long as the FROM/TO WDT is refreshed, the FROM/TO LED will be On. After power On or after a WDT error, the FROM/TO LED will be off until the next FROM/TO command is registered. After the FROM/TO watchdog timer error has occurred, the value in the WDT register (BFM #26) must be refreshed. Otherwise it is not possible to go online and exchange valid data with the network.

If an WDT error has occurred and FROM/TO traffic is recognized before BFM #26 is reset, the FROM/TO LED will flicker.

If the WDT is disabled (BFM #26 = 0) and no FROM/TO command from the PLC are received, the FROM/TO LED will be switched off 200ms after the last FROM/TO command was processed.

### 6.1.3 The RUN LED

The RUN LED is controlled by the BUS\_OFF and the BUS\_OK state of the CAN controller. When the module experiences too many transmission errors (for example, a baud rate mismatch), it will go to the BUS\_OFF state (CAN error number > 255). In the BUS\_OFF state, the RUN LED is OFF. After an internal software reset and a minimum of 128 bus free signals, the module changes into BUS\_OK state (RUN LED is ON).

### 6.1.4 The Rx/Tx LED

This LED lights up when the module is exchanging data. If the module is in the Pre-operational state, the Tx/Rx LED is OFF. In the operational state, the Tx/Rx LED is ON. If an internal queue overrun occurs, the TxRxLED will start to flicker.

### 6.1.5 The ERROR LED

This LED lights up on a general error.

Check the CAN cable, the connectors, the end of the line terminal resistors, and the status of the bus management mode. Also check BFM #29 for error bits. After the module enters the data exchange state, if there are no errors and the module is in the BUS\_OK state, the LED is switched off.

In case of a BUS\_OFF error, a general hardware error (BFM #29, bit 0) or if the FROM/TO watchdog is expired, the LED will always be ON.

The LED will flicker if the FX<sub>2N</sub>-32CAN is in error passive state (CAN error counter >128) or on an internal queue overflow.

A flickering ERROR LED does not mean there is a permanent error.

After the node changes from error passive to error active state the LED will be switched off.

In case of an transmit or command queue overflow the error is displayed until the corresponding latched error flags (b8,b9) in BFM #29 are reset and no new queue overflow occurs.

# MEMO

## 7. Example Program

The programs shown below are examples of how to set parameters and exchange data on the CANopen Bus using the FX<sub>2N</sub>-32CAN module. The examples for Mode A Mapping in sections 7.3 and 7.4 can also be downloaded into two CANopen nodes and used to exchange data. Please remember that these Mode “0”, “A”, and “B” Mapping Modes were developed to use with the FX<sub>2N</sub>-32CAN modules and other CANopen nodes will not have these special settings.

Large networks or networks with many types of nodes can be configured more quickly and easily if using a commercially available CANopen configuration tool.

The SDO write command in Section 7.1 gives an example of how to access the CANopen Object Dictionary through the BFM<sub>s</sub> of the FX<sub>2N</sub>-32CAN module. The object dictionary can also be accessed through a configuration tool.

## 7.1 SDO Write Command

The CANopen Object Dictionary specifies where data and parameters are stored by Index and Sub-Index number. Information can be stored or network parameters set/changed by writing values to the appropriate Index and Sub-Index. The SDO command is one method to write the data.

The programming example below shows how to write the command to start all nodes on CANopen network bus. The code can be copied with appropriate data changes to perform other SDO write commands.

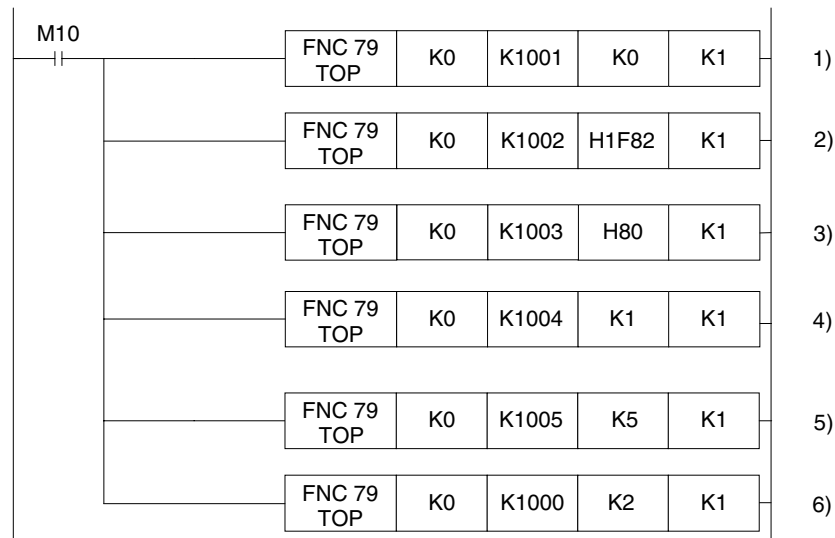

- 1) The command must be passed through the BFM to the CANopen Object Dictionary. Node "0" is used to default to the local node. In general this BFM is used to specify which node number (1~127) is the target for the SDO access.
- 2) Write the Index number. In this example, H18F2 is the node start up command index. In order to perform other network functions, please study the CANopen Object Dictionary and write to the appropriate Index.
- 3) Write to the Sub-index. In this example, the nodes to be started is decided and the value 80H defaults to "all nodes".
- 4) Write the amount of data to be transferred. The value K1 means that one byte of data will be transferred.
- 5) Write the actual data to be transferred, the low byte of BFM #1005 = 1st data Byte; high byte of BFM #1005 = 2nd data Byte. The value 5H is the signal to turn on the specified nodes.
- 6) Write the data to the CANopen network. Up to this point, the data has only been stored in the FX<sub>2</sub>N-32CAN BFMs.

## 7.2 Mode 0 Mapping Command

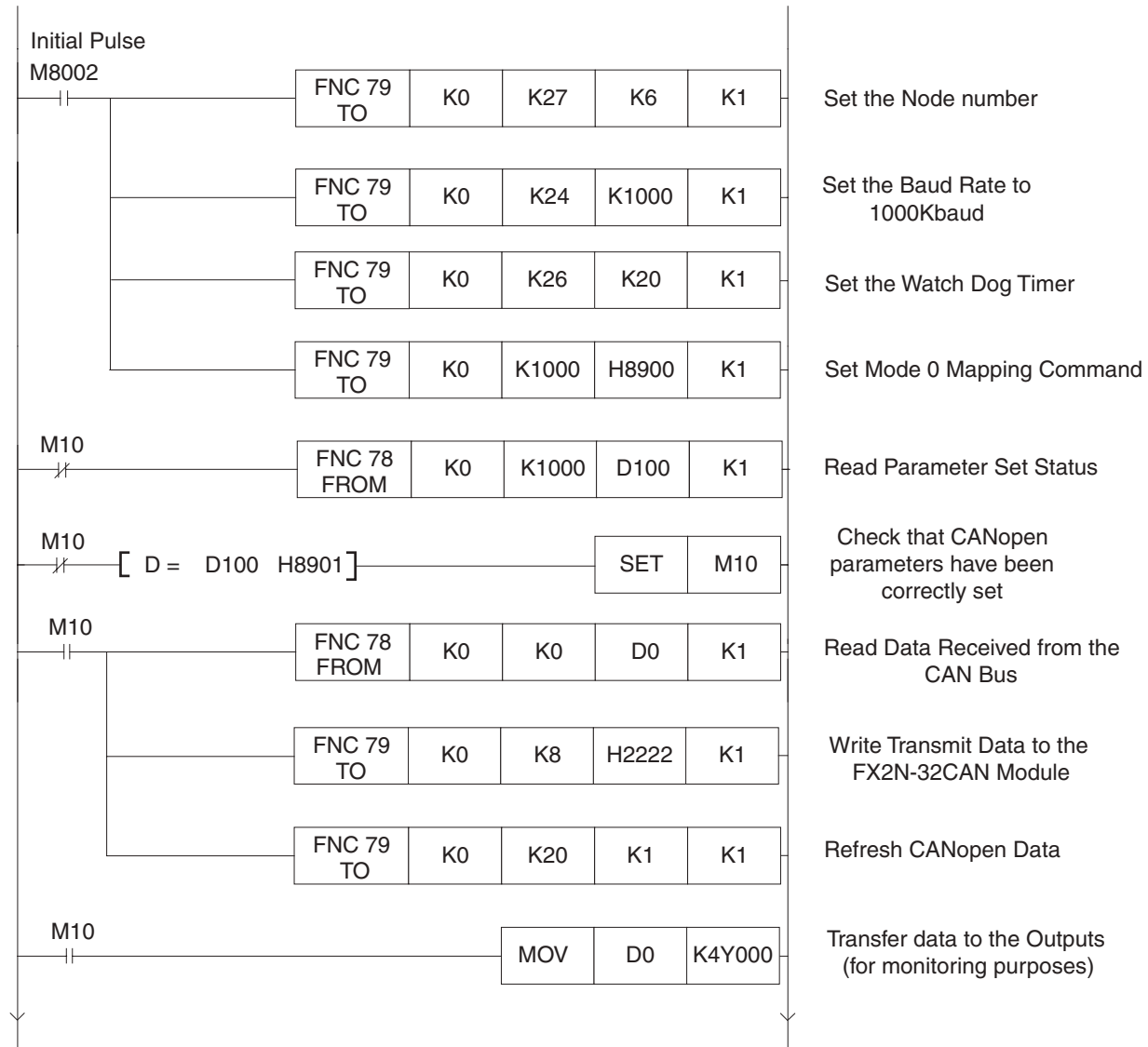



### 7.3 Mode A Mapping Example

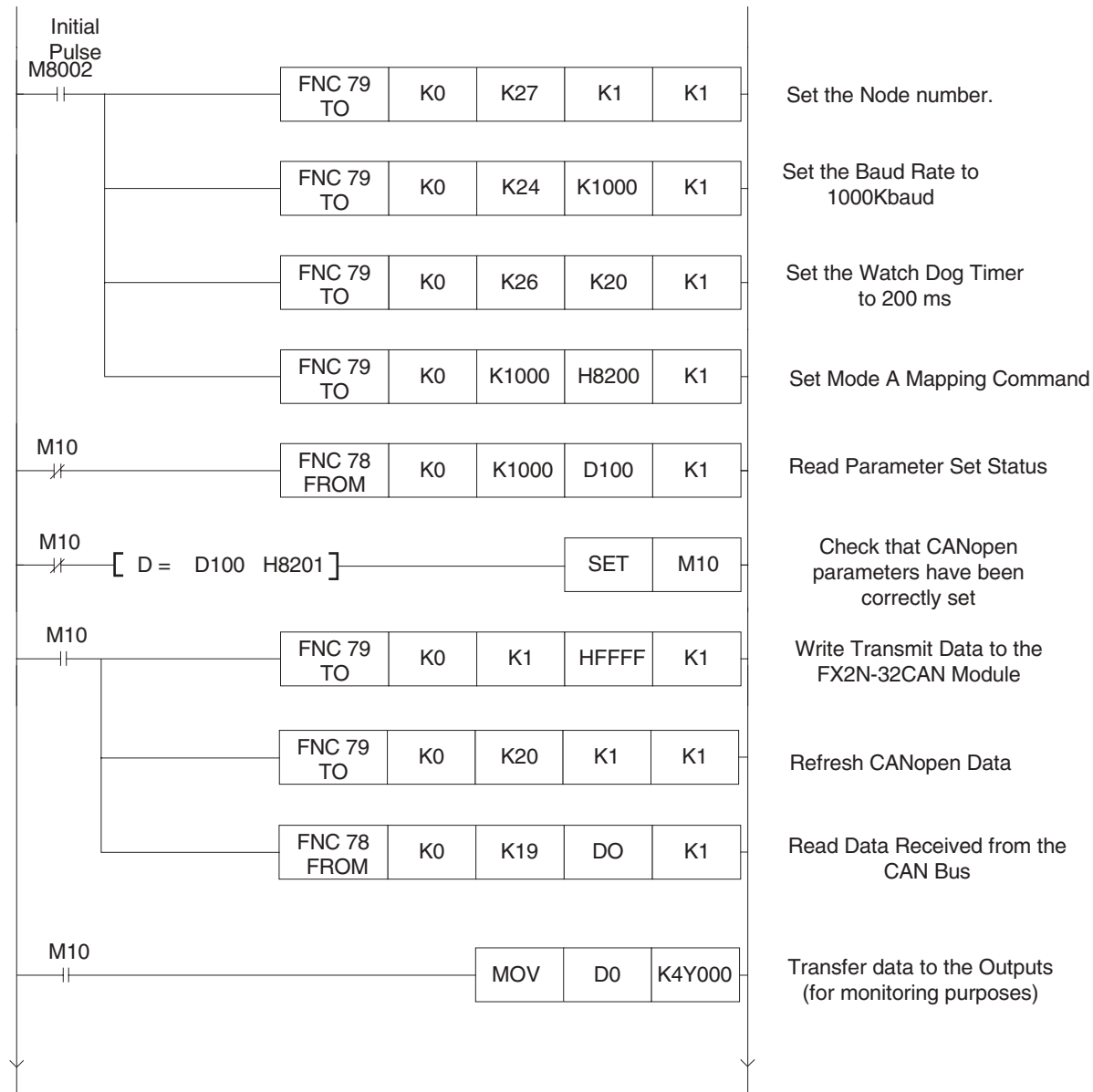

### 7.4 Mode A Mapping with Node Start Up Command

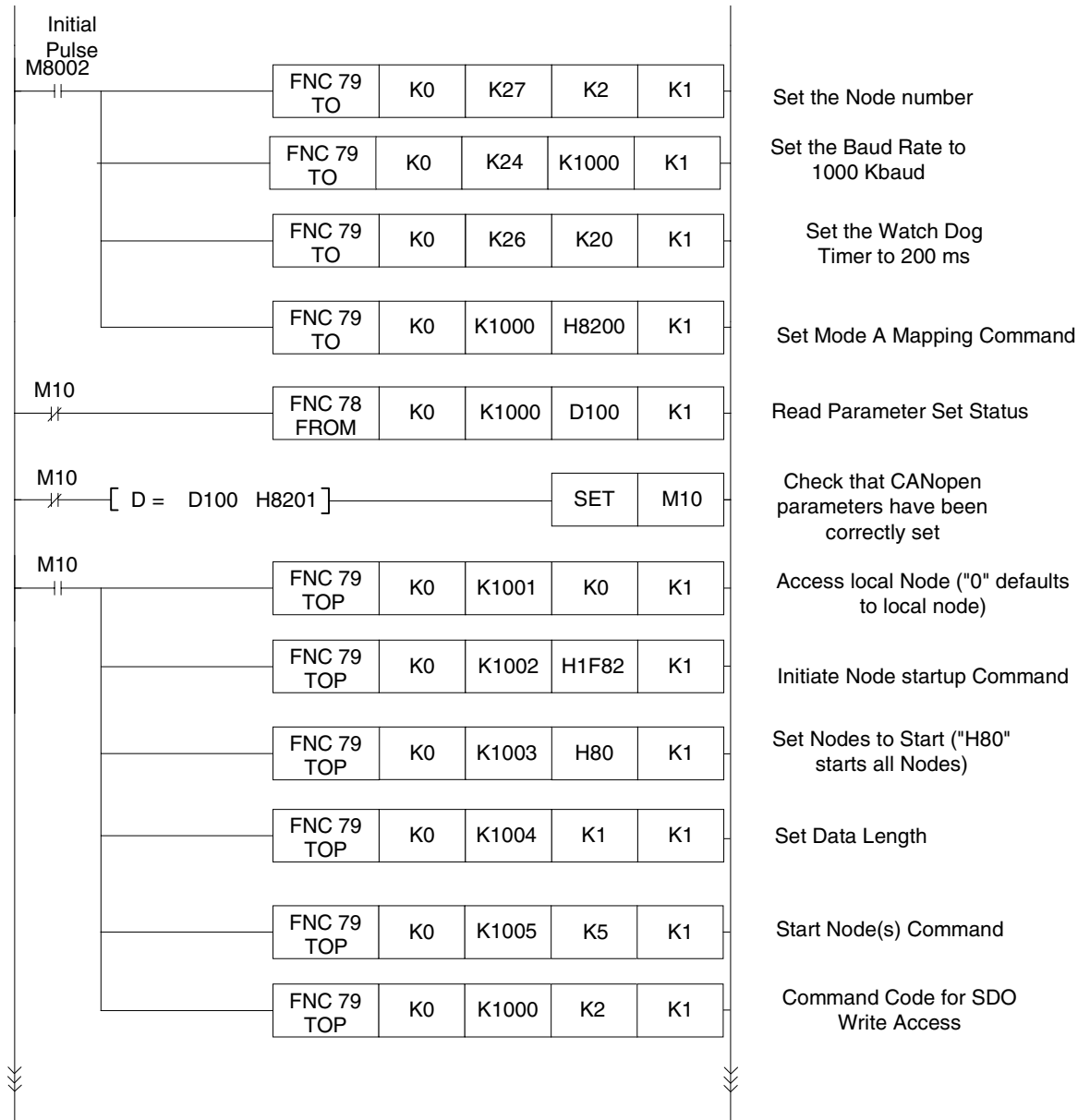

Continued.....

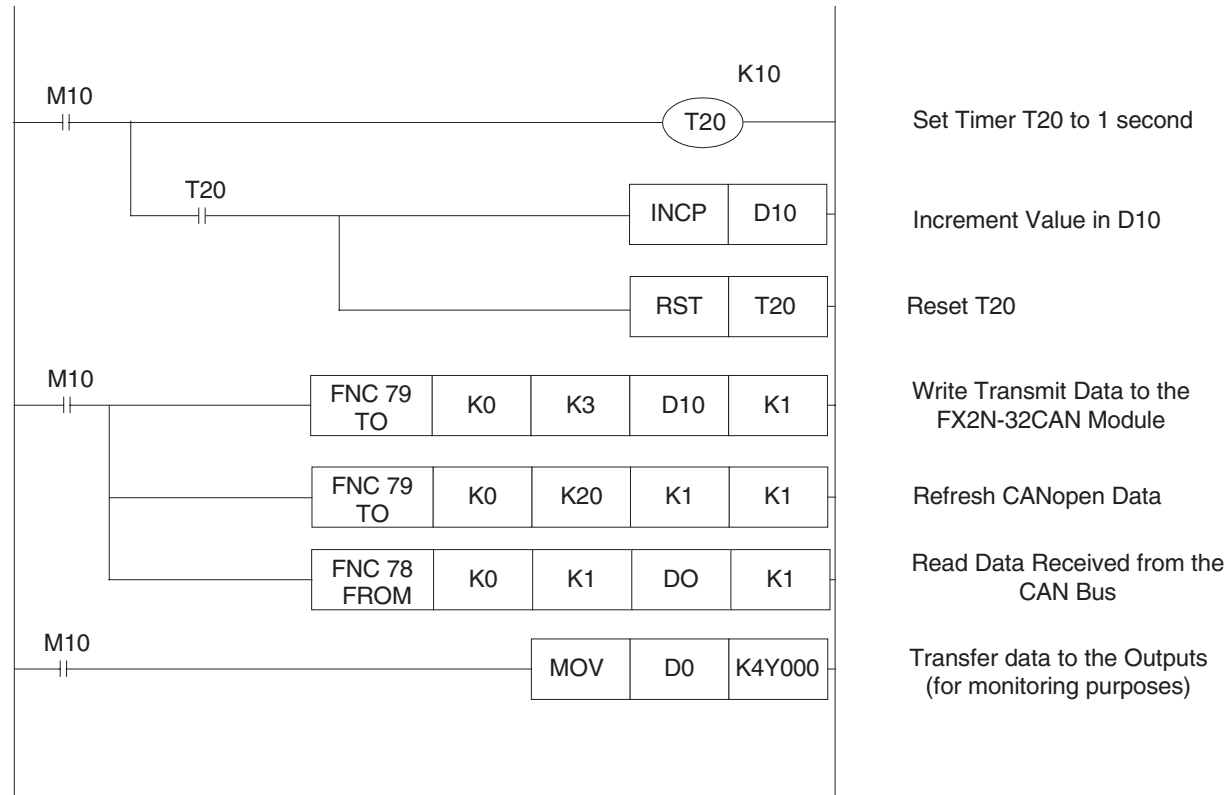

## 7.5 Mode B Mapping Example with SDO Command

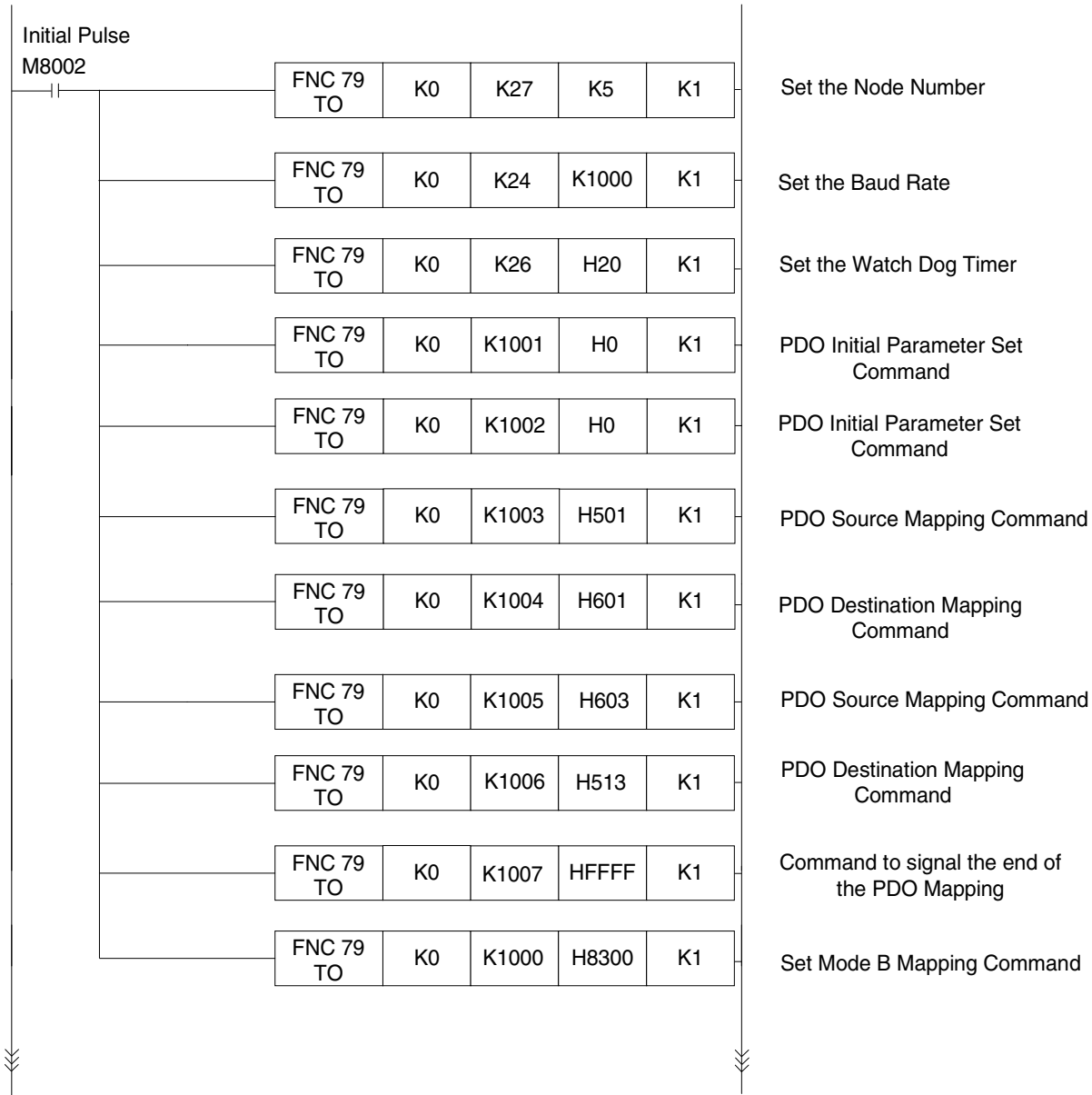

Continued.....

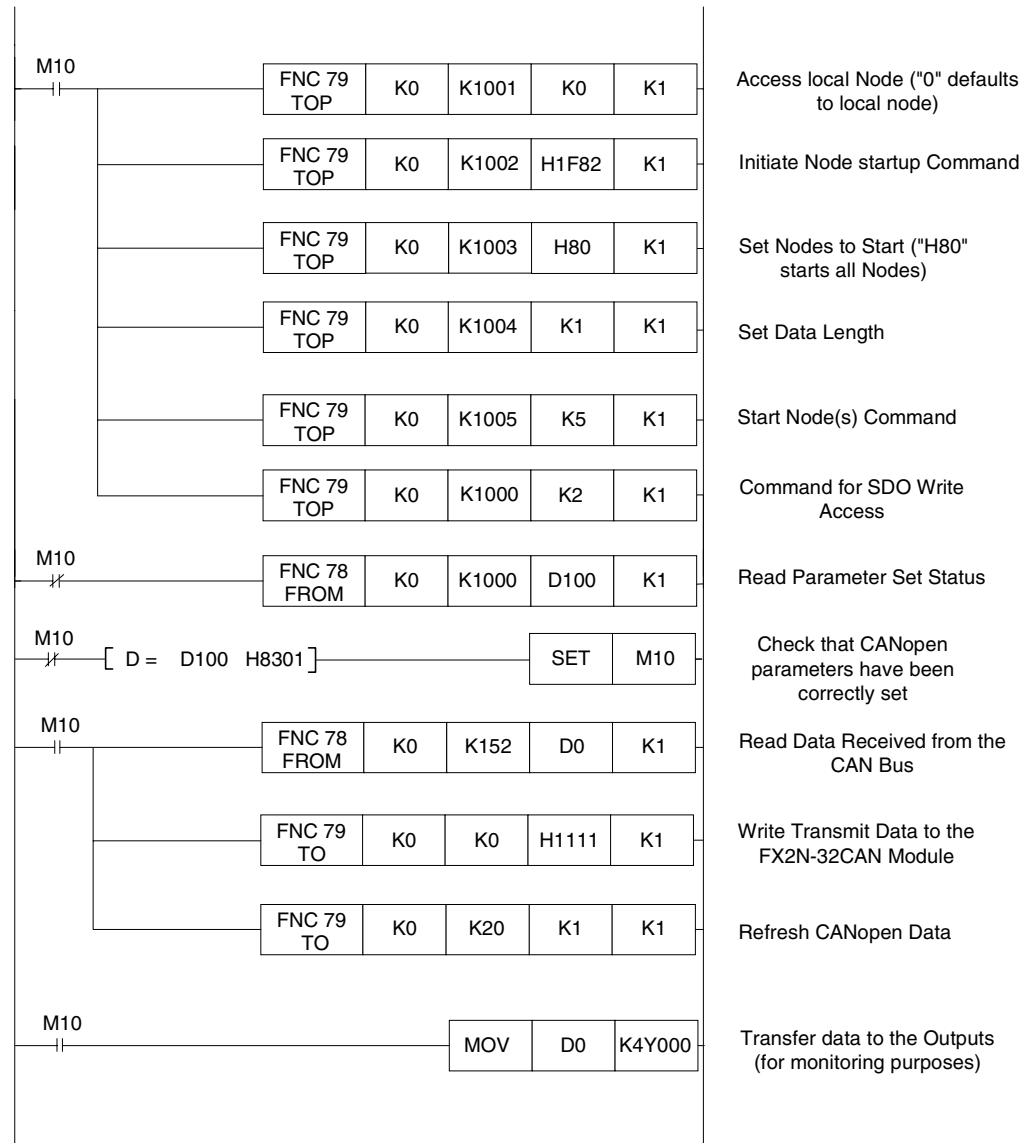

# MEMO

## Appendix A: Further Information Manual Lists

**Table A-1: Further Information Manual Lists**

Manual name	Manual No.	Description
FX2N-32CAN User's Manual	JY992D92801	This manual contains explanations for BFM of FX2N-32CAN.
FX2N Series Hardware Manual	JY992D66301	This manual contains explanations for wiring, installation and specification, etc. about FX2N Series PLC.
FX1N Series Hardware Manual	JY992D89301	This manual contains explanations for wiring, installation and specification, etc. about FX1N Series PLC.
FX Series of Programming Manual II	JY992D88101	This manual contains explanations for the basic instructions, applied instructions and various devices of FX1S, FX1N, FX2N and FX2NC Series PLC.
FX3U Series User's Manual - Hardware Edition	JY997D16501	This manual contains explanations for wiring, installation and specification, etc. about FX3U Series PLC.
FX3UC Series User's Manual - Hardware Edition	JY997D28701	This manual contains explanations for wiring, installation and specification, etc. about FX3UC Series PLC.
FX3G Series User's Manual - Hardware Edition	JY997D31301	This manual contains explanations for wiring, installation and specification, etc. about FX3G Series PLC.

**Table A-1: Further Information Manual Lists**

Manual name	Manual No.	Description
FX3G/FX3U/FX3UC Series Programming Manual - Basic & Applied Instruction Edition	JY997D16601	This manual contains explanations for the basic instructions, applied instructions and various devices of the FX3G/FX3U/FX3UC Series PLC.
MELSEC-Q/L/F Structured Programming Manual (Fundamentals)	SH-080782	This manual contains explanations for the programming method, types of programming languages and other information required to create structured programs.
FX CPU Structured Programming Manual (Device & Common)	JY997D26001	This manual contains explanations for the devices and parameters provided in GX Works2 for structured programming.
FX CPU Structured Programming Manual (Basic & Applied Instruction)	JY997D34701	This manual contains explanations for the sequence instructions provided in GX Works2 for structured programming.
FX CPU Structured Programming Manual (Application Functions)	JY997D34801	This manual contains explanations for the application functions provided in GX Works2 for structured programming.





# HARDWARE MANUAL

FX<sub>2</sub>N-32CAN Communication Module



HEAD OFFICE: TOKYO BUILDING, 2-7-3 MARUNOUCHI, CHIYODA-KU, TOKYO 100-8310, JAPAN  
HIMEJI WORKS: 840, CHIYODA CHO, HIMEJI, JAPAN

JY992D92901D  
(MEE)

Effective Nov. 2010  
Specification are subject to change without notice.