

This manual contains text, diagrams and explanations which will guide the reader in the correct installation and operation of the FX2N-232AWC-NP PROTOCOL INTERFACE. It should be read and understood before attempting to install or use the unit. Further information can be found in the FX series PLC hardware manuals.

1. Introduction

FX2N-232AWC-NP is the protocol interface to forward sequence programs and monitor operations of FX series controllers in the CC-Link network.

This interface is connected to the CC-Link system by way of the peripheral connection unit AJ65BT-G4.

Industrial automation

Elincom Group

 European Union: www.elinco.eu

 Russia: www.elinc.ru

2. System configuration

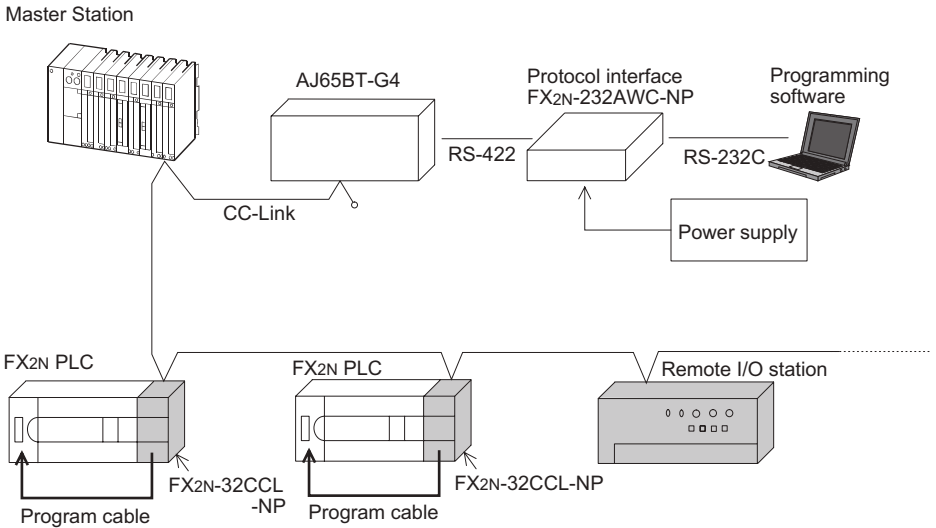

3. Dimensions and setting

Dimensions: mm (inches)

Mass (weight): 0.2 kg (0.44 lbs)

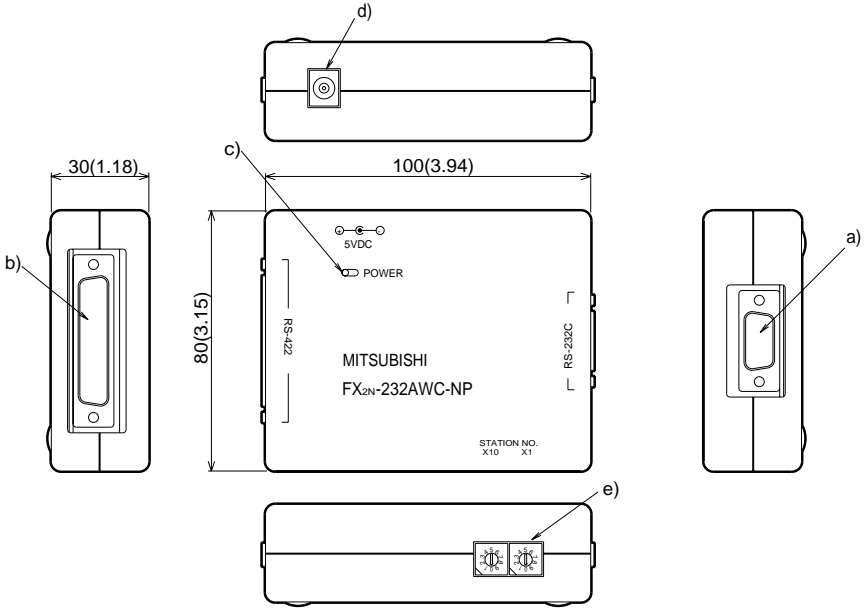

- a) RS-232C port : 9-pin D-Sub (pin)
- b) RS-422 port : 25-pin D-Sub (socket)
- c) Power indicator : 5V DC is supplied from the outside.
- d) 5V DC external power supply: 5V DC \pm 5% (200 mA)
Applicable connector plug

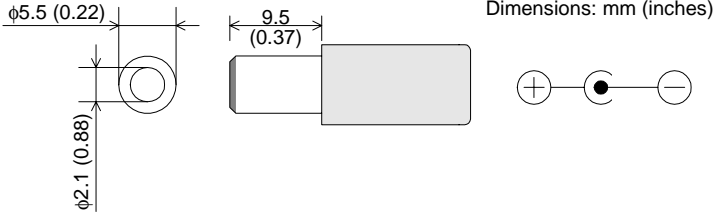

- e) Station number setting switch: For reading and writing programs.
For setting the station number of FX2N-32CCL-NP.

4. Wiring

4.1 RS-232C

FX2N-232AWC-NP 9-pin D-Sub connector (pin)	Wiring diagram of FX-232CAB-1 Lengths 3.0m (9.8ft)	Connected to
2: RD 3: SD 4: ER 5: SG 6: DR Others pins have no connections.		Computer

4.2 RS-422

FX2N-232AWC-NP 25-pin D-Sub connector (socket)	Wiring diagram of FX-422CAB Lengths 0.3m (1.0ft)	Connected to
2 : SDA 3 : RDA 4 : ERA 5 : DRA 15: SDB 16: RDB 17: ERB 18: DRB 7, 8, 20: SG Others pins have no connections.		AJ65BT-G4

5. Setting of AJ65BT-G4

Item		Setting	
BAUD RATE		The same baud rate as CC-Link.	
STATION NUMBER		Sets the station number of the module.	
SW	1	ON	Mode: Q Test mode: On line
	2	OFF	
	3	OFF	
	4	OFF	
	5	OFF	
	6	OFF	
	7	OFF	
	8	OFF	

6. Specifications

6.1 General Specification

Dielectric strength: 500V AC for 1 minute (between the case and the PLC ground)
Other specification is equivalent to that of the PLC main unit.

6.2 Specifications of power supply

Line voltage	5V DC±5% (Supplied from the outside.)
Current consumption	200 mA
Isolation	Photocoupler and transformer isolation between the communication

7. Transfer with PLC

- For communication with PLC, communication program must be operating normally.
No communication by FX2N-232AWC-NP is allowed when the master station has a link error.
- Writing the programs to FX series PLC is not possible in the "RUN" state. Reading the programs, however, is possible in the "RUN" state.
To run and stop operations in the FX series PLC, it is suggested to use the "Remote RUN/STOP" from the programming software.
- Runtime program changes from the programming software are not possible.
- If programs are lost as in the situation of a dead battery, programs can be changed via CC-Link but the remote RUN operation is not available.
In this case, use the PLC RUN/STOP switch. In order to avoid program loss, M8005 or M8006 should be monitored and appropriate steps taken.

Manual number : JY992D98301

Manual revision : A

Date : April 2001

 **MITSUBISHI ELECTRIC CORPORATION**

HEAD OFFICE : MITSUBISHI DENKI BLDG MARUNOUTI TOKYO 100-8310 TELEX : J24532 CABLE MELCO TOKYO
HIMEJI WORKS : 840, CHIYODA CHO, HIMEJI, JAPAN

FX2N

FX2N-232AWC-NP PROTOCOL INTERFACE

USER'S MANUAL

JY992D98301A

This manual contains text, diagrams and explanations which will guide the reader in the correct installation and operation of the FX2N-232AWC-NP PROTOCOL INTERFACE. It should be read and understood before attempting to install or use the unit. Further information can be found in the FX series PLC hardware manuals.

1. Introduction

FX2N-232AWC-NP is the protocol interface to forward sequence programs and monitor operations of FX series controllers in the CC-Link network.

This interface is connected to the CC-Link system by way of the peripheral connection unit AJ65BT-G4.

2. System configuration

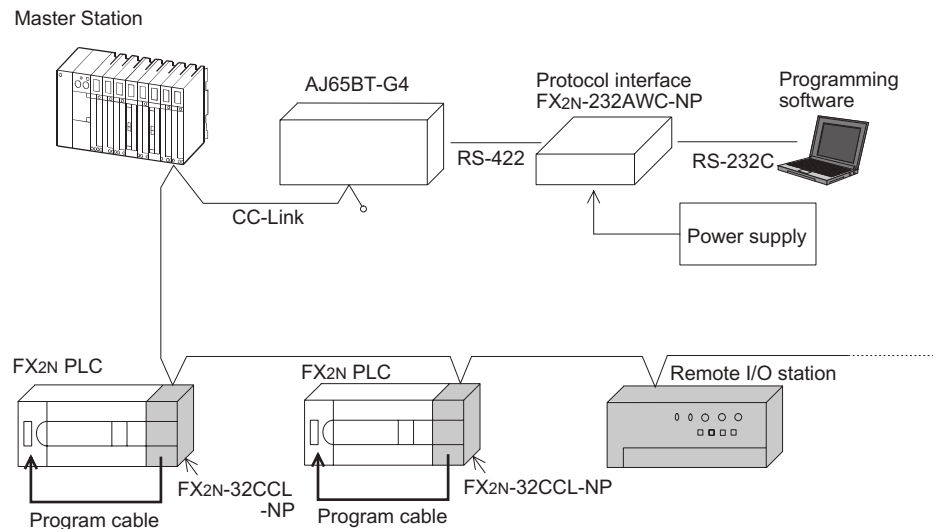

3. Dimensions and setting

Dimensions: mm (inches)

Mass (weight): 0.2 kg (0.44 lbs)

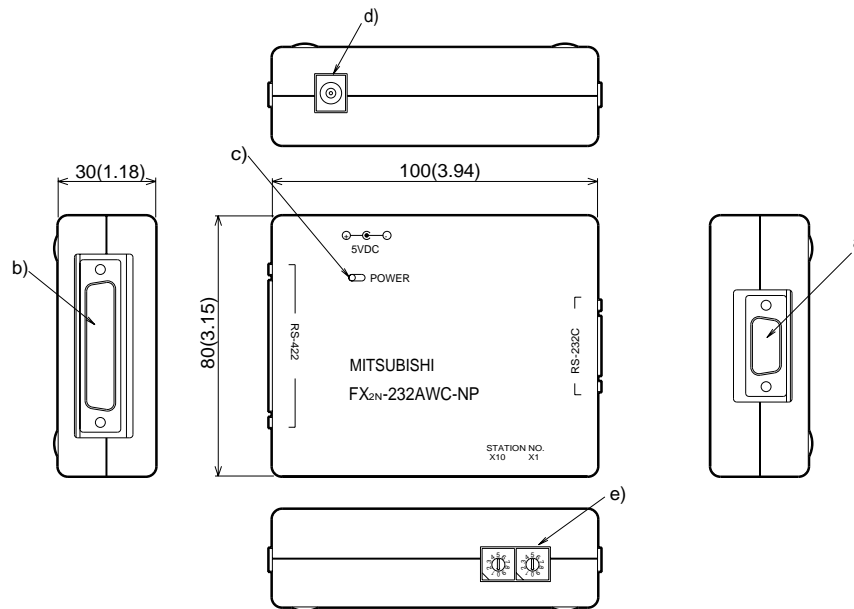

- a) RS-232C port : 9-pin D-Sub (pin)
- b) RS-422 port : 25-pin D-Sub (socket)
- c) Power indicator : 5V DC is supplied from the outside.
- d) 5V DC external power supply : 5V DC ±5% (200 mA)
Applicable connector plug

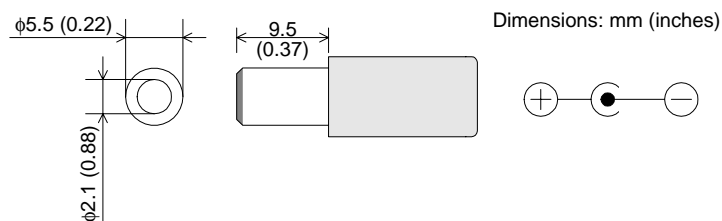

- e) Station number setting switch: For reading and writing programs.
For setting the station number of FX2N-32CCL-NP.

4. Wiring

4.1 RS-232C

FX2N-232AWC-NP 9-pin D-Sub connector (pin)	Wiring diagram of FX-232CAB-1 Lengths 3.0m (9.8ft)	Connected to
2: RD 3: SD 4: ER 5: SG 6: DR Others pins have no connections.		Computer

4.2 RS-422

FX2N-232AWC-NP 25-pin D-Sub connector (socket)	Wiring diagram of FX-422CAB Lengths 0.3m (1.0ft)	Connected to
2 : SDA 3 : RDA 4 : ERA 5 : DRA 15: SDB 16: RDB 17: ERB 18: DRB 7, 8, 20: SG Others pins have no connections.		AJ65BT-G4

5. Setting of AJ65BT-G4

Item	Setting	
BAUD RATE	The same baud rate as CC-Link.	
STATION NUMBER	Sets the station number of the module.	
SW	1 ON	Mode: Q
	2 OFF	
	3 OFF	
	4 OFF	
	5 OFF	Test mode: On line
	6 OFF	
	7 OFF	
	8 OFF	

6. Specifications

6.1 General Specification

Dielectric strength: 500V AC for 1 minute (between the case and the PLC ground)
Other specification is equivalent to that of the PLC main unit.

6.2 Specifications of power supply

Line voltage	5V DC±5% (Supplied from the outside.)
Current consumption	200 mA
Isolation	Photocoupler and transformer isolation between the communication

7. Transfer with PLC

- a) For communication with PLC, communication program must be operating normally.
No communication by FX2N-232AWC-NP is allowed when the master station has a link error.
- b) Writing the programs to FX series PLC is not possible in the "RUN" state. Reading the programs, however, is possible in the "RUN" state.
To run and stop operations in the FX series PLC, it is suggested to use the "Remote RUN/STOP" from the programming software.
- c) Runtime program changes from the programming software are not possible.
- d) If programs are lost as in the situation of a dead battery, programs can be changed via CC-Link but the remote RUN operation is not available.
In this case, use the PLC RUN/STOP switch. In order to avoid program loss, M8005 or M8006 should be monitored and appropriate steps taken.

Manual number : JY992D98301

Manual revision : A

Date : April 2001

MITSUBISHI ELECTRIC CORPORATION

HEAD OFFICE : MITSUBISHI DENKI BLDG MARUNOUTI TOKYO 100-8310 TELEX : J24532 CABLE MELCO TOKYO
HIMEJI WORKS : 840, CHIYODA CHO, HIMEJI, JAPAN