



Side A JAPANESE
Side B ENGLISH

PROGRAMMABLE CONTROLLERS
MELSEC-F

FX-30P

INSTALLATION MANUAL



Manual Number	JY997D34201
Revision	F
Date	April 2015

This manual describes the part names, dimensions, and specifications of the product. Before use, read this manual and manuals of relevant products fully to acquire proficiency in handling and operating the product. Make sure to learn all the product information, safety information, and precautions. And, store this manual in a safe place so that you can take it out and read it whenever necessary. Always forward it to the end user.

Registration:
The company name and the product name to be described in this manual are the registered trademarks or trademarks of each company.

Effective April 2015
Specifications are subject to change without notice.
© 2008 Mitsubishi Electric Corporation

Safety Precautions (Read these precautions before use.)

This manual classifies the safety precautions into two categories:

WARNING and **CAUTION**

	Indicates that incorrect handling may cause hazardous conditions, resulting in death or severe injury.
	Indicates that incorrect handling may cause hazardous conditions, resulting in medium or slight personal injury or physical damage.

Depending on circumstances, procedures indicated by **CAUTION** may also cause severe injury. It is important to follow all precautions for personal safety.

Associated Manuals

Manual name	Manual No.	Description
FX3U Series User's Manual - Hardware Edition	JY997D16501 MODEL CODE: 09R516	Explains the FX3U Series PLC specifications for I/O, wiring, installation, and maintenance.
FX3UC Series User's Manual - Hardware Edition	JY997D28701 MODEL CODE: 09R519	Explains the FX3UC Series PLC specifications for I/O, wiring, installation, and maintenance.
FX3G Series User's Manual - Hardware Edition	JY997D31301 MODEL CODE: 09R521	Explains the FX3G Series PLC specifications for I/O, wiring, installation, and maintenance.
FX3GC Series User's Manual - Hardware Edition	JY997D45401 MODEL CODE: 09R533	Explains the FX3GC Series PLC specifications for I/O, wiring, installation, and maintenance.
FX3S Series User's Manual - Hardware Edition	JY997D48601 MODEL CODE: 09R535	Explains the FX3S Series PLC specifications for I/O, wiring, installation, and maintenance.
FX2N HARDWARE MANUAL	JY992D66301 MODEL CODE: 09R508	This manual contains hardware explanations for wiring, installation and specification for FX2N series PLC
FX2NC (D/U/L) HARDWARE MANUAL	JY992D87201	This manual contains hardware explanations for wiring, installation and specification for FX2NC (D/U/L) series PLC
FX2NC (DSS/DS) HARDWARE MANUAL	JY992D76401 MODEL CODE: 09R509	This manual contains hardware explanations for wiring, installation and specification for FX2NC (DSS/DS) series PLC

Manual name	Manual No.	Description
FX1N HARDWARE MANUAL	JY992D89301 MODEL CODE: 09R511	This manual contains hardware explanations for wiring, installation and specification for FX1N series PLC
FX1S HARDWARE MANUAL	JY992D83901 MODEL CODE: 09R510	This manual contains hardware explanations for wiring, installation and specification for FX1S series PLC
FX0/FX0N HARDWARE MANUAL	JY992D47501	This manual contains hardware explanations for wiring, installation and specification for FX0/FX0N series PLC
FX0S HARDWARE MANUAL	JY992D55301	This manual contains hardware explanations for wiring, installation and specification for FX0S series PLC
FX-SERIES HARDWARE MANUAL	JY992D47401	This manual contains hardware explanations for wiring, installation and specification for FX series PLC
FX0/FX0S/FX0N/FX/FX2C/FX2N/FX2NC PROGRAMMING MANUAL	JY992D48301	This manual contains instruction explanations for the FX series PLC
FX1S/FX1N/FX2N/FX2NC PROGRAMMING MANUAL II	JY992D88101 MODEL CODE: 09R512	This manual contains instruction explanations for the FX series PLC
FX3S/FX3G/FX3U/FX3GC/FX3UC Series Programming Manual - Basic & Applied Instruction Edition	JY997D16601 MODEL CODE: 09R517	Describes PLC programming for basic/applied instructions and devices.
FX-30P Operation Manual	JY997D34401 MODEL CODE: 09R924	Describes FX-30P type Handy programming panel details.

How to obtain manuals

For product manuals or documents, contact the Mitsubishi Electric dealer from whom you purchased your product.

Certification of UL, cUL standards

FX-30P units comply with the UL standards (UL, cUL).
UL, cUL File Number: E95239

Regarding the standards that comply with the main unit, please refer to either the FX series product catalog or consult with your nearest Mitsubishi product provider.

Compliance with EC directive (CE Marking)

This note does not guarantee that an entire mechanical module produced in accordance with the contents of this note will comply with the following standards. Compliance to EMC directive and LVD directive for the entire mechanical module should be checked by the user/manufacturer. For more information please consult with your nearest Mitsubishi product provider.

Regarding the standards that comply with the main unit, please refer to either the FX series product catalog or consult with your nearest Mitsubishi product provider.

Requirement for Compliance with EMC directive

The following products have shown compliance through direct testing (of the identified standards below) and design analysis (through the creation of a technical construction file) to the European Directive for Electromagnetic Compatibility (2004/108/EC) when used as directed by the appropriate documentation.

Attention

- This product is designed for use in industrial applications.

Note

- Authorized Representative in the European Community: Mitsubishi Electric Europe B.V. Gothaer Str. 8, 40880 Ratingen, Germany

Elincom Group

European Union: www.elinco.eu

Russia: www.elinc.ru

Type: Programmable Controller (Open Type Equipment)
Models: MELSEC FX series manufactured from December 1st, 2008
FX-30P

Standard	Remark
EN61131-2:2007 Programmable controllers - Equipment requirements and tests	Compliance with all relevant aspects of the standard. EMI • Radiated Emission • Conducted Emission EMS • Radiated electromagnetic field • Fast transient burst • Electrostatic discharge • High-energy surge • Voltage drops and interruptions • Conducted RF • Power frequency magnetic field

Caution for EC Directive

Attach the ferrite core to the communication cables (PLC side). Attach the ferrite core in approximately 100mm(3.93") or less from connector on the PLC side.
For the ferrite core use the following product or one with equivalent specifications.
Model name: ZCAT2035-0930 (Manufactured by TDK co., Ltd.)

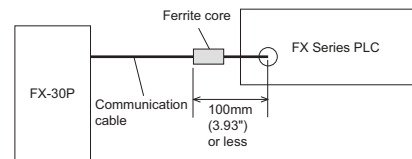

1. Introduction

Mitsubishi Handy Programming Panel FX-30P (hereafter abbreviated as "FX-30P") is a handheld unit to edit programs, monitor and test devices, etc. for a connected FX Series PLC.

→ For system configuration, refer to the FX-30P Operation Manual.

1.1 Major Features of the FX-30P

- The FX-30P is a compact, handheld program monitor.
- The FX-30P displays the program/PLC operation status (monitor), operation guidance and error messages on the LC display of 21 half-width characters by 8 lines.
- The FX-30P offers online mode and offline mode. The FX-30P directly accesses the memory of the connected PLC in online mode, and accesses the built-in RAM in offline mode.
- The FX-30P can back up programs written in offline mode using the built-in battery.
- The FX-30P has a built-in flash memory to save up to 15 programs. The program management function can read out programs saved in the flash memory to the built-in RAM, write programs from the built-in RAM to the flash memory, and delete programs.
- The FX-30P offers list format for writing and reading programs and displaying monitored devices.

1.2 Incorporated Items

Check to ensure the following product and items are included in the package:

Included Items	
FX-30P	1 unit
FX-20P-CAB0 (cable)	1 cable
Manuals [Japanese version, English version]	1 manual each

1.3 External Dimensions and Part Names

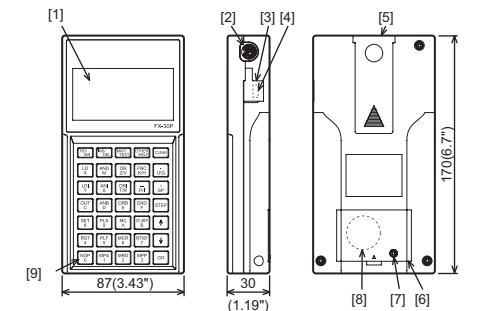

Unit: mm(inches)
MASS(Weight): 0.3kg(0.66lbs)

- LCD display (With backlight)
- PLC communication port
- USB cover
- USB communication port
- Slide hook
- Battery cover
- Screw for battery cover anchoring
- FX3U-32BL type battery (standard accessory)
- Key

1.4 Key layout

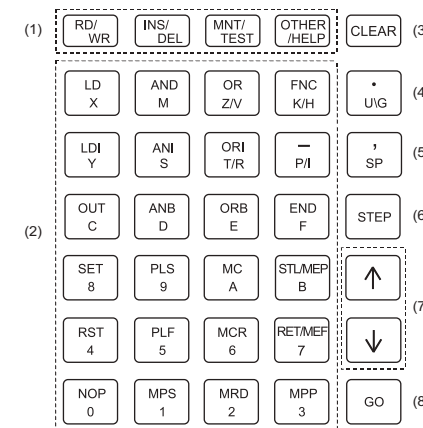

- Function keys (read/write, insert/delete, monitor/test and other/help): Each key operates alternately.
- Instruction keys, device symbol keys and numeric keys: Instruction keys are provided in the upper position of each key, and numeric and device number keys are provided in the lower position of each key.
- [Clear] key: Use this key to cancel the key input before pressing the [GO] key (before confirmation), clear an error message, or return to the previous screen.
- This key is provided to aid device symbol input. Use this key to directly specify a buffer memory or specify a device bit.
- [Space] key: Use this key to enter space in the entry column, specify a device or specify a constant.
- [Step] key: Use this key to specify the step number.
- Cursor control keys: Use these keys to move the line cursor and prompt, specify a device before or after the currently specified device, or scroll lines. Press and hold a cursor control key for 1 second or more to achieve continuous input.
- [GO] key: Use this key to confirm or execute a command, scroll the screen after display, or perform a search again.

2. Installation

INSTALLATION PRECAUTIONS	 CAUTION
<ul style="list-style-type: none"> Use the product within the generic environment specifications described in section 3.2 of this manual. Never use the product in areas with excessive dust, oily smoke, conductive dusts, corrosive gas (salt air, Cl₂, H₂S, SO₂, or NO₂), flammable gas, vibration or impacts, or expose it to high temperature, condensation, or rain and wind. If the product is used in such conditions, electric shock, fire, malfunctions, deterioration or damage may occur. Do not touch the conductive parts of the product directly. Doing so may cause device failures or malfunctions. Connect cables securely to their designated connectors. Loose connections may cause malfunctions. Do not connect a PLC and a personal computer at the same time to the FX-30P. Failure to do so may cause equipment failures or malfunctions. 	

For details on the installation, refer to the following manual.

→ Refer to the FX-30P Operation Manual.

2.1 Connection to a PLC

The FX-30P can be connected to the programming port of the main unit. Refer to the manual of the connected PLC and the FX-30P Operation Manual for details.

2.2 Connection to a personal computer

The FX-30P can be connected to the USB port of the personal computer.

For details, refer to the FX-30P Operation Manual.

3. Specification

For details on specifications, refer to the following manual.

→ Refer to the FX-30P Operation Manual.

DESIGN PRECAUTIONS	 CAUTION
<ul style="list-style-type: none"> When executing control (data changes) to an operating PLC, construct an interlock circuit in the sequence program so that the entire system operates conservatively. Additionally, when executing control such as program changes and operation status changes (status control) to an operating PLC, thoroughly read the manual and sufficiently confirm safety in advance. Make sure to have the following safety circuits outside the PLC to ensure safe system operation even during external power supply problems or PLC failure. Otherwise, malfunctions may cause serious accidents. <ol style="list-style-type: none"> Most importantly, have the following: an emergency stop circuit, a protection circuit, an interlock circuit for opposite movements (such as normal vs. reverse rotation), and an interlock circuit (to prevent damage to the equipment at the upper and lower positioning limits). Note that when the PLC CPU detects an error, such as a watchdog timer error, during self-diagnosis, all outputs are turned off. Also, when an error that cannot be detected by the PLC CPU occurs in an input/output control block, output control may be disabled. External circuits and mechanisms should be designed to ensure safe machinery operation in such cases. 	

DESIGN PRECAUTIONS	 CAUTION
<ul style="list-style-type: none"> Observe the following items. Failure to do so may cause incorrect data-writing through noise to the PLC and result in PLC failure, machine damage or other accidents. <ol style="list-style-type: none"> Do not bundle the control line together with or lay it close to the main circuit or power line. As a guideline, lay the control line at least 100mm (3.94") or more away from the main circuit or power line. Noise may cause malfunctions. Ground the shield wire or shield of a shielded cable. Do not use common grounding with heavy electrical systems. Install module so that excessive force will not be applied to the power connector. Failure to do so may result in wire damage/breakage or PLC failure. 	

STARTUP AND MAINTENANCE PRECAUTIONS	 CAUTION
<ul style="list-style-type: none"> Turn off the power to the PLC before attaching or detaching the battery. Doing so may cause equipment failures, or malfunctions. Use the battery for memory backup correctly in conformance to the manual of each product. <ul style="list-style-type: none"> Use the battery only for the specified purpose. Connect the battery correctly. Do not charge, disassemble, heat, put in fire, short-circuit, connect reversely, weld, swallow or burn the battery, or apply excessive forces (vibration, impact, drop, etc.) to the battery. Do not store or use the battery at high temperatures or expose to direct sunlight. Do not expose to water, bring near fire or touch liquid leakage or other contents directly. Incorrect handling of the battery may cause heat excessive generation, bursting, ignition, liquid leakage or deformation, and lead to injury, fire or failures and malfunctions of facilities and other equipment. Before modifying or disrupting the program in operation or running the PLC, carefully read through this manual and the associated manuals and ensure the safety of the operation. An operation error may damage the machinery or cause accidents. Do not change the program in the PLC from two or more peripheral equipment devices at the same time. (i.e. from a programming tool and a GOT) Doing so may cause malfunction of the PLC program. 	

STARTUP AND MAINTENANCE PRECAUTIONS	 CAUTION
<ul style="list-style-type: none"> Do not disassemble or modify the PLC. Doing so may cause fire, equipment failures, or malfunctions. For repair, contact your local Mitsubishi Electric representative. Turn off the power to the PLC before connecting or disconnecting cable. Failure to do so may cause equipment failures or malfunctions. 	

DISPOSAL PRECAUTIONS	 CAUTION
<ul style="list-style-type: none"> Please contact a certified electronic waste disposal company for the environmentally safe recycling and disposal of your device. When disposing of batteries, separate them from other waste according to local regulations. (For details of the Battery Directive in EU countries, refer to FX-30P Operation Manual.) 	

TRANSPORTATION AND STORAGE PRECAUTIONS	 CAUTION
<ul style="list-style-type: none"> The FX-30P is a precision instrument. During transportation, avoid impacts larger than those specified in the general specifications (refer to Section 3.2) of this manual. Failure to do so may cause failures in the FX-30P. After transportation, verify the operations of the FX-30P. Before transporting the FX-30P, make sure to turn on the power of the FX-30P, and confirm that an HPP battery voltage low error does not occur (or confirm that the HPP battery voltage is 2.7 V or more). If the FX-30P is transported when the battery voltage is low and the battery life is expired, the battery-backed data may not be held correctly during transportation. When transporting lithium batteries, follow required transportation regulations. (For details of the regulated products, refer to FX-30P Operation Manual.) 	

3.1 Applicable PLC

Model name
FX1/FX2(FX)/FX2C/FX0/FX0S/FX0N/FX1S/FX1N/FX1NC/FX2N/FX2NC/FX3S/FX3G/FX3GC/FX3U/FX3UC Series PLC ¹

¹ An FX-20P-CAB is necessary to connect the FX-30P with the FX1/FX2(FX)/FX2C PLC.

3.2 General Specifications

Item	Specification			
Ambient temperature	0 to 40°C (32 to 104°F)			
Ambient humidity	5 to 95%RH (no condensation) when operating			
Storage ambient temperature	-25 to 75°C (-13 to 167°F)			
Storage ambient humidity	5 to 95%RH (no condensation)			
Vibration resistance ^{*1}	Frequency (Hz)	Acceleration (m/s ²)	Half amplitude (mm)	Sweep Count for X, Y, Z: 10 times (80 min in each direction)
	5 to 9	-	3.5	
	9 to 150	9.8	-	
Shock resistance ^{*1}	147m/s ² Acceleration, Action time: 11ms, 3 times by half-sine pulse in each direction X, Y, and Z			
Noise resistance	By noise simulator at noise voltage of 1,000Vp-p, noise width of 1ms, rise time of 1ns and period of 30 to 100Hz			
Working atmosphere	Free from corrosive or flammable gas and excessive conductive dust			
Working altitude	<2000m ^{*2}			

^{*1} The criterion is shown in IEC61131-2.

^{*2} The PLC cannot be used at a pressure higher than the atmospheric pressure to avoid damage.

3.3 Power Supply Specification

Item		Specification	
External power supply	Power supply voltage	5V DC ±5% (Power supply is supplied from PLC or personal computer. ^{*1})	
	Current consumption	supplied from PLC	155mA (When the intensity of LCD backlight is set at the maximum value 8) 115mA (When the intensity of LCD backlight is set at the initial value 4)
		supplied from personal computer.	165mA (When the intensity of LCD backlight is set at the maximum value 8) 125mA (When the intensity of LCD backlight is set at the initial value 4)

^{*1} Power supply by bus power

3.4 Performance Specification

Item	Specification	
Display unit	Type	STN monochrome (white/black) liquid crystal
	Resolution	128x64 dots
	Display size	W66.54(2.62) x H33.26(1.31)[mm](inch)
	Foreground color	Monochrome (white/black)
Backlight	White	
Buzzer	9-level adjustment (including the buzzer OFF level)	
Contrast adjustment	8-level adjustment	
Intensity of LCD	9-level adjustment (including the backlight OFF level)	
Key figure	35 pieces	
Memory	Program capacity	Built-in RAM: 64K step RAM retention (for about five years, ambient temperature 25°C(77°F)) by battery. Built-in flash memory: Up to 15 programs can be stored in the built-in flash memory. Allowable number of writes: 100000 times
	FX-30P held data	Language display setting (Japanese/English/Chinese), contrast, buzzer volume, intensity control, screen save, HPP protect key (saved in the flash memory)

3.5 Communication specification

Item		Specification
For PLC communication	Communications standard	Serial RS-422 standard practice compliant 1ch
	Transmission speed	115.2/57.6/38.4/19.2/9.6kbps
	Connector shape configuration	RS-422 mini DIN 8 pin female
For personal computer communication	Communications standard	USB 2.0/1.1 standard practice compliant 1ch
	Transmission speed	115.2kbps after serial conversion.
	Connector shape configuration	USB mini B plug female

This manual confers no industrial property rights or any rights of any other kind, nor does it confer any patent licenses. Mitsubishi Electric Corporation cannot be held responsible for any problems involving industrial property rights which may occur as a result of using the contents noted in this manual.

Warranty

Mitsubishi will not be held liable for damage caused by factors found not to be the cause of Mitsubishi; opportunity loss or lost profits caused by faults in the Mitsubishi products; damage, secondary damage, accident compensation caused by special factors unpredictable by Mitsubishi; damages to products other than Mitsubishi products; and to other duties.

 For safe use
<ul style="list-style-type: none"> This product has been manufactured as a general-purpose part for general industries, and has not been designed or manufactured to be incorporated in a device or system used in purposes related to human life. Before using the product for special purposes such as nuclear power, electric power, aerospace, medicine or passenger movement vehicles, consult with Mitsubishi Electric. This product has been manufactured under strict quality control. However when installing the product where major accidents or losses could occur if the product fails, install appropriate backup or failsafe functions in the system.

MITSUBISHI ELECTRIC CORPORATION

HEAD OFFICE : TOKYO BUILDING, 2-7-3 MARUNOUCHI, CHIYODA-KU, TOKYO 100-8310, JAPAN



JAPANESE
ENGLISH

PROGRAMMABLE CONTROLLERS

FX-30P

INSTALLATION MANUAL



Manual Number	JY997D34201
Revision	F
Date	April 2015

This manual describes the part names, dimensions, and specifications of the product. Before use, read this manual and manuals of relevant products fully to acquire proficiency in handling and operating the product. Make sure to learn all the product information, safety information, and precautions. And, store this manual in a safe place so that you can take it out and read it whenever necessary. Always forward it to the end user.

Registration: The company name and the product name to be described in this manual are the registered trademarks or trademarks of each company.

Safety Precautions (Read these precautions before use.)

This manual classifies the safety precautions into two categories:

⚠ WARNING and ⚠ CAUTION

⚠ WARNING	Indicates that incorrect handling may cause hazardous conditions, resulting in death or severe injury.
⚠ CAUTION	Indicates that incorrect handling may cause hazardous conditions, resulting in medium or slight personal injury or physical damage.

Depending on circumstances, procedures indicated by ⚠ CAUTION may also cause severe injury. It is important to follow all precautions for personal safety.

Associated Manuals

Manual name	Manual No.	Description
FX3U Series User's Manual - Hardware Edition	JY997D16501 MODEL CODE: 09R516	Explains the FX3U Series PLC specifications for I/O, wiring, installation, and maintenance.
FX3UC Series User's Manual - Hardware Edition	JY997D28701 MODEL CODE: 09R519	Explains the FX3UC Series PLC specifications for I/O, wiring, installation, and maintenance.
FX3C Series User's Manual - Hardware Edition	JY997D31301 MODEL CODE: 09R521	Explains the FX3C Series PLC specifications for I/O, wiring, installation, and maintenance.
FX3GC Series User's Manual - Hardware Edition	JY997D45401 MODEL CODE: 09R533	Explains the FX3GC Series PLC specifications for I/O, wiring, installation, and maintenance.
FX3S Series User's Manual - Hardware Edition	JY997D48601 MODEL CODE: 09R535	Explains the FX3S Series PLC specifications for I/O, wiring, installation, and maintenance.
FX2N HARDWARE MANUAL	JY992D66301 MODEL CODE: 09R508	This manual contains hardware explanations for wiring, installation and specification for FX2N series PLC
FX2NC (D/U/L) HARDWARE MANUAL	JY992D87201	This manual contains hardware explanations for wiring, installation and specification for FX2NC (D/U/L) series PLC
FX2NC (DSS/DS) HARDWARE MANUAL	JY992D76401 MODEL CODE: 09R509	This manual contains hardware explanations for wiring, installation and specification for FX2NC (DSS/DS) series PLC

Manual name	Manual No.	Description
FX1N HARDWARE MANUAL	JY992D89301 MODEL CODE: 09R511	This manual contains hardware explanations for wiring, installation and specification for FX1N series PLC
FX1S HARDWARE MANUAL	JY992D83901 MODEL CODE: 09R510	This manual contains hardware explanations for wiring, installation and specification for FX1S series PLC
FX0/FX0N HARDWARE MANUAL	JY992D47501	This manual contains hardware explanations for wiring, installation and specification for FX0/FX0N series PLC
FX0S HARDWARE MANUAL	JY992D55301	This manual contains hardware explanations for wiring, installation and specification for FX0S series PLC
FX-SERIES HARDWARE MANUAL	JY992D47401	This manual contains hardware explanations for wiring, installation and specification for FX series PLC
FX0/FX0S/FX0N/FX2C/FX2N/FX2NC PROGRAMMING MANUAL	JY992D48301	This manual contains instruction explanations for the FX series PLC
FX1S/FX1N/FX2N/FX2NC PROGRAMMING MANUAL II	JY992D88101 MODEL CODE: 09R512	This manual contains instruction explanations for the FX series PLC
FX3S/FX3G/FX3U/FX3GC/FX3UC Series Programming Manual - Basic & Applied Instruction Edition	JY997D16601 MODEL CODE: 09R517	Describes PLC programming for basic/applied instructions and devices.
FX-30P Operation Manual	JY997D34401 MODEL CODE: 09R924	Describes FX-30P type Handy programming panel details.

How to obtain manuals
For product manuals or documents, contact the Mitsubishi Electric dealer from whom you purchased your product.

Certification of UL, cUL standards

FX-30P units comply with the UL standards (UL, cUL).
UL, cUL File Number: E95239
Regarding the standards that comply with the main unit, please refer to either the FX series product catalog or consult with your nearest Mitsubishi product provider.

Compliance with EC directive (CE Marking)

This note does not guarantee that an entire mechanical module produced in accordance with the contents of this note will comply with the following standards. Compliance to EMC directive and LVD directive for the entire mechanical module should be checked by the user/manufacturer. For more information please consult with your nearest Mitsubishi product provider. Regarding the standards that comply with the main unit, please refer to either the FX series product catalog or consult with your nearest Mitsubishi product provider.

Requirement for Compliance with EMC directive

The following products have shown compliance through direct testing (of the identified standards below) and design analysis (through the creation of a technical construction file) to the European Directive for Electromagnetic Compatibility (2004/108/EC) when used as directed by the appropriate documentation.

Attention

- This product is designed for use in industrial applications.

Note

- Authorized Representative in the European Community:
Mitsubishi Electric Europe B.V.
Gothaer Str. 8, 40880 Ratingen, Germany

Type: Programmable Controller (Open Type Equipment)
Models: MELSEC FX series manufactured from December 1st, 2008
FX-30P

Standard	Remark
EN61131-2:2007 Programmable controllers - Equipment requirements and tests	Compliance with all relevant aspects of the standard. EMI • Radiated Emission • Conducted Emission EMS • Radiated electromagnetic field • Fast transient burst • Electrostatic discharge • High-energy surge • Voltage drops and interruptions • Conducted RF • Power frequency magnetic field

Caution for EC Directive

Attach the ferrite core to the communication cables (PLC side). Attach the ferrite core in approximately 100mm(3.93") or less from connector on the PLC side.
For the ferrite core use the following product or one with equivalent specifications.
Model name:ZCAT2035-0930 (Manufactured by TDK co., Ltd.)

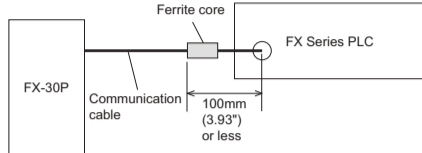

1. Introduction

Mitsubishi Handy Programming Panel FX-30P (hereafter abbreviated as "FX-30P") is a handheld unit to edit programs, monitor and test devices, etc. for a connected FX Series PLC.

→ For system configuration, refer to the FX-30P Operation Manual.

1.1 Major Features of the FX-30P

- The FX-30P is a compact, handheld program monitor.
- The FX-30P displays the program/PLC operation status (monitor), operation guidance and error messages on the LC display of 21 half-width characters by 8 lines.
- The FX-30P offers online mode and offline mode.
The FX-30P directly accesses the memory of the connected PLC in online mode, and accesses the built-in RAM in offline mode.
- The FX-30P can back up programs written in offline mode using the built-in battery.
- The FX-30P has a built-in flash memory to save up to 15 programs.
The program management function can read out programs saved in the flash memory to the built-in RAM, write programs from the built-in RAM to the flash memory, and delete programs.
- The FX-30P offers list format for writing and reading programs and displaying monitored devices.

1.2 Incorporated Items

Check to ensure the following product and items are included in the package:

Included Items	
FX-30P	1 unit
FX-20P-CAB0 (cable)	1 cable
Manuals [Japanese version, English version]	1 manual each

1.3 External Dimensions and Part Names

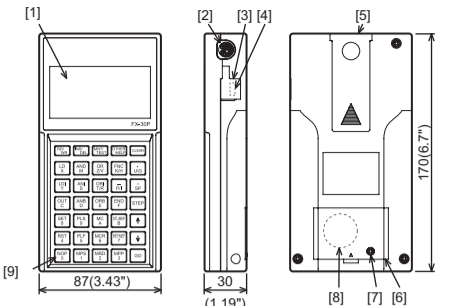

- Unit: mm(inches)
MASS(Weight): 0.3kg(0.66lbs)
- LCD display (With backlight)
 - PLC communication port
 - USB cover
 - USB communication port
 - Slide hook
 - Battery cover
 - Screw for battery cover anchoring
 - FX3U-32BL type battery (standard accessory)
 - Key

1.4 Key layout

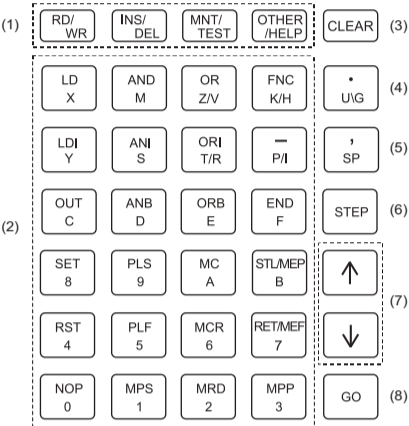

- Function keys (read/write, insert/delete, monitor/test and other/help): Each key operates alternately.
- Instruction keys, device symbol keys and numeric keys: Instruction keys are provided in the upper position of each key, and numeric and device number keys are provided in the lower position of each key.
- [Clear] key: Use this key to cancel the key input before pressing the [GO] key (before confirmation), clear an error message, or return to the previous screen.
- This key is provided to aid device symbol input. Use this key to directly specify a buffer memory or specify a device bit.
- [Space] key: Use this key to enter space in the entry column, specify a device or specify a constant.
- [Step] key: Use this key to specify the step number.
- Cursor control keys: Use these keys to move the line cursor and prompt, specify a device before or after the currently specified device, or scroll lines. Press and hold a cursor control key for 1 second or more to achieve continuous input.
- [GO] key: Use this key to confirm or execute a command, scroll the screen after display, or perform a search again.

2. Installation

INSTALLATION PRECAUTIONS	⚠ CAUTION
<ul style="list-style-type: none"> Use the product within the generic environment specifications described in section 3.2 of this manual. Never use the product in areas with excessive dust, oily smoke, conductive dusts, corrosive gas (salt air, Cl₂, H₂S, SO₂, or NO₂), flammable gas, vibration or impacts, or expose it to high temperature, condensation, or rain and wind. If the product is used in such conditions, electric shock, fire, malfunctions, deterioration or damage may occur. Do not touch the conductive parts of the product directly. Doing so may cause device failures or malfunctions. Connect cables securely to their designated connectors. Loose connections may cause malfunctions. Do not connect a PLC and a personal computer at the same time to the FX-30P. Failure to do so may cause equipment failures or malfunctions. 	<p>For details on the installation, refer to the following manual.</p> <p>→ Refer to the FX-30P Operation Manual.</p>

→ Refer to the FX-30P Operation Manual.

2.1 Connection to a PLC

The FX-30P can be connected to the programming port of the main unit. Refer to the manual of the connected PLC and the FX-30P Operation Manual for details.

2.2 Connection to a personal computer

The FX-30P can be connected to the USB port of the personal computer. For details, refer to the FX-30P Operation Manual.

3. Specification

For details on specifications, refer to the following manual.

→ Refer to the FX-30P Operation Manual.

DESIGN PRECAUTIONS	⚠ WARNING
<ul style="list-style-type: none"> When executing control (data changes) to an operating PLC, construct an interlock circuit in the sequence program so that the entire system operates conservatively. Additionally, when executing control such as program changes and operation status changes (status control) to an operating PLC, thoroughly read the manual and sufficiently confirm safety in advance. Make sure to have the following safety circuits outside the PLC to ensure safe system operation even during external power supply problems or PLC failure. Otherwise, malfunctions may cause serious accidents. 1) Most importantly, have the following: an emergency stop circuit, a protection circuit, an interlock circuit for opposite movements (such as normal vs. reverse rotation), and an interlock circuit (to prevent damage to the equipment at the upper and lower positioning limits). 2) Note that when the PLC CPU detects an error, such as a watchdog timer error, during self-diagnosis, all outputs are turned off. Also, when an error that cannot be detected by the PLC CPU occurs in an input/output control block, output control may be disabled. External circuits and mechanisms should be designed to ensure safe machinery operation in such cases. 	<p>For details on the installation, refer to the following manual.</p> <p>→ Refer to the FX-30P Operation Manual.</p>

DESIGN PRECAUTIONS	⚠ CAUTION
<ul style="list-style-type: none"> Observe the following items. Failure to do so may cause incorrect data-writing through noise to the PLC and result in PLC failure, machine damage or other accidents. 1) Do not bundle the control line together with or lay it close to the main circuit or power line. As a guideline, lay the control line at least 100mm (3.94") or more away from the main circuit or power line. Noise may cause malfunctions. 2) Ground the shield wire or shield of a shielded cable. Do not use common grounding with heavy electrical systems. Install module so that excessive force will not be applied to the power connector. Failure to do so may result in wire damage/breakage or PLC failure. 	

STARTUP AND MAINTENANCE PRECAUTIONS	⚠ WARNING
<ul style="list-style-type: none"> Turn off the power to the PLC before attaching or detaching the battery. Doing so may cause equipment failures, or malfunctions. Use the battery for memory backup correctly in conformance to the manual of each product. - Use the battery only for the specified purpose. - Connect the battery correctly. - Do not charge, disassemble, heat, put in fire, short-circuit, connect reversely, weld, swallow or burn the battery, or apply excessive forces (vibration, impact, drop, etc.) to the battery. - Do not store or use the battery at high temperatures or expose to direct sunlight. - Do not expose to water, bring near fire or touch liquid leakage or other contents directly. - Incorrect handling of the battery may cause heat excessive generation, bursting, ignition, liquid leakage or deformation, and lead to injury, fire or failures and malfunctions of facilities and other equipment. Before modifying or disrupting the program in operation or running the PLC, carefully read through this manual and the associated manuals and ensure the safety of the operation. An operation error may damage the machinery or cause accidents. Do not change the program in the PLC from two or more peripheral equipment devices at the same time. (i.e. from a programming tool and a GOT) Doing so may cause malfunction of the PLC program. 	

STARTUP AND MAINTENANCE PRECAUTIONS	⚠ CAUTION
<ul style="list-style-type: none"> Do not disassemble or modify the PLC. Doing so may cause fire, equipment failures, or malfunctions. For repair, contact your local Mitsubishi Electric representative. Turn off the power to the PLC before connecting or disconnecting cable. Failure to do so may cause equipment failures or malfunctions. 	

DISPOSAL PRECAUTIONS	⚠ CAUTION
<ul style="list-style-type: none"> Please contact a certified electronic waste disposal company for the environmentally safe recycling and disposal of your device. When disposing of batteries, separate them from other waste according to local regulations. (For details of the Battery Directive in EU countries, refer to FX-30P Operation Manual.) 	

TRANSPORTATION AND STORAGE PRECAUTIONS	⚠ CAUTION
<ul style="list-style-type: none"> The FX-30P is a precision instrument. During transportation, avoid impacts larger than those specified in the general specifications (refer to Section 3.2) of this manual. Failure to do so may cause failures in the FX-30P. After transportation, verify the operations of the FX-30P. Before transporting the FX-30P, make sure to turn on the power of the FX-30P, and confirm that an HPP battery voltage low error does not occur (or confirm that the HPP battery voltage is 2.7 V or more). If the FX-30P is transported when the battery voltage is low and the battery life is expired, the battery-backed data may not be held correctly during transportation. When transporting lithium batteries, follow required transportation regulations. (For details of the regulated products, refer to FX-30P Operation Manual.) 	

3.1 Applicable PLC

Model name
FX1/FX2(FX)/FX2C/FX0/FX0S/FX0N/FX1S/FX1N/FX1NC/FX2N/FX2NC/FX3S/FX3G/ FX3GC/FX3U/FX3UC Series PLC ¹⁾

¹⁾ An FX-20P-CAB is necessary to connect the FX-30P with the FX1/FX2(FX)/FX2C PLC.

3.2 General Specifications

Item	Specification
Ambient temperature	0 to 40°C (32 to 104°F)
Ambient humidity	5 to 95%RH (no condensation) when operating
Storage ambient temperature	-25 to 75°C (-13 to 167°F)
Storage ambient humidity	5 to 95%RH (no condensation)
Vibration resistance ^{*1}	Frequency (Hz) Acceleration (m/s ²) Half amplitude (mm) Sweep Count for X, Y, Z: (10 times (80 min in each direction))
Shock resistance ^{*1}	147m/s ² Acceleration, Action time: 11ms, 3 times by half-sine pulse in each direction X, Y, and Z
Noise resistance	By noise simulator at noise voltage of 1,000Vp-p, noise width of 1ms, rise time of 1ns and period of 30 to 100Hz
Working atmosphere	Free from corrosive or flammable gas and excessive conductive dust
Working altitude	<2000m ²

^{*1} The criterion is shown in IEC61131-2.

^{*2} The PLC cannot be used at a pressure higher than the atmospheric pressure to avoid damage.

3.3 Power Supply Specification

Item	Specification
Power supply voltage	5V DC ±5% (Power supply is supplied from PLC or personal computer. ^{*1})
Current consumption	supplied from PLC 155mA (When the intensity of LCD backlight is set at the maximum value 8) 115mA (When the intensity of LCD backlight is set at the initial value 4)
	supplied from personal computer. 165mA (When the intensity of LCD backlight is set at the maximum value 8) 125mA (When the intensity of LCD backlight is set at the initial value 4)

^{*1} Power supply by bus power

3.4 Performance Specification

Item	Specification
Display unit	Type: STN monochrome (white/black) liquid crystal
	Resolution: 128x64 dots
	Display size: W66.54(2.62) x H33.26(1.31)[mm](inch)
Foreground color	Monochrome (white/black)
Backlight	White
Buzzer	9-level adjustment (including the buzzer OFF level)
Contrast adjustment	8-level adjustment
Intensity of LCD	9-level adjustment (including the backlight OFF level)
Key figure	35 pieces
Memory	Program capacity Built-in RAM: 64K step RAM retention (for about five years, ambient temperature 25°C(77°F)) by battery. Built-in flash memory: Up to 15 programs can be stored in the built-in flash memory. Allowable number of writes: 100000 times
	FX-30P held data Language display setting (Japanese/English/Chinese), contrast, buzzer volume, intensity control, screen save, HPP protect key (saved in the flash memory)

3.5 Communication specification

Item	Specification	
For PLC communication	Communications standard	Serial RS-422 standard practice compliant 1ch
	Transmission speed	115.2/57.6/38.4/19.2/9.6kbps
	Connector shape configuration	RS-422 mini DIN 8 pin female
For personal computer communication	Communications standard	USB 2.0/1.1 standard practice compliant 1ch
	Transmission speed	115.2kbps after serial conversion.
	Connector shape configuration	USB mini B plug female

This manual confers no industrial property rights or any rights of any other kind, nor does it confer any patent licenses. Mitsubishi Electric Corporation cannot be held responsible for any problems involving industrial property rights which may occur as a result of using the contents noted in this manual.

Warranty
Mitsubishi will not be held liable for damage caused by factors found not to be the cause of Mitsubishi; opportunity loss or lost profits caused by faults in the Mitsubishi products; damage, secondary damage, accident compensation caused by special factors unpredictable by Mitsubishi; damages to products other than Mitsubishi products; and to other duties.

⚠ For safe use

- This product has been manufactured as a general-purpose part for general industries, and has not been designed or manufactured to be incorporated in a device or system used in purposes related to human life.
- Before using the product for special purposes such as nuclear power, electric power, aerospace, medicine or passenger movement vehicles, consult with Mitsubishi Electric.
- This product has been manufactured under strict quality control. However when installing the product where major accidents or losses could occur if the product fails, install appropriate backup or failsafe functions in the system.